

VDF Universal Precision Turning Machines Series D.

**Swing over bed:
425, 485 or 530 mm.
24 spindle speeds: 11.2 to 2240 rpm.
Diameter of spindle bore: 62 mm.
Diameter of spindle
in front bearing: 100 mm.
Diameter of tailstock quill:
70 and 80 mm MT 5.
A.C. main drive: 11 kW.
Torque: max. 1600 Nm.**

VDF

BOEHRINGER
Göppingen.

Precision and quality have their price, also in a conventional engine lathe. Why we succeeded in keeping that price at a moderate level and make a very popular lathe is explained in the following.

The precision lathes of the series D are the „small fry“ among the comprehensive VDF manufacturing program of turning machines (but nevertheless they are well suited for longitudinal, transverse, external and internal operations, for threading, copying, heavy roughing and precise finishing cuts). A sales program which – in the meantime – covers 7 series of 21 sizes in total for Boehringer and Wohlenberg combined (see Page 15).

Of course, their technical data, specifications, performance and technological success are not as spectacular as those of their bigger „sisters“, and they were more or less forced to play a somewhat secluded, overshadowed role as run-of-the-mill lathes. And still, they are definitely no „wall-flowers“. To the contrary: they run, and work, tirelessly and most reliably. The D machines are without doubt one type of lathes „Made in Germany“ which we can pride ourselves of having sold in greater numbers in their category and size than any other maker. This success is not least due to „how“ they run: very smoothly, maintaining lifelong accuracy thanks to their superior perfection in general and down to the slightest detail. (This statement is proved by the fact that on the market of used machines they are sold at top prices, if offered at all. In most cases they change hands through other, private channels).

The machines of the series D are indeed the embodiment of a classical universal lathe (carefully tended to by us for more than 130 years), and enjoying a good reputation as a top product of German machine tool engineering, worldwide. A VDF original and model example for precision and quality.

Also available with increased tool-room accuracy to DIN 8605. – Surely some attributes of value and importance also for the 80s.

The D machines are identical in concept, operation and maintenance – based on a universal building block system for the customers' benefit, and a reasonable relation between price and performance. Or, in other words: much machine for your money.



The machines are made by highly qualified „craftsmen“ of long experience, meaning: even if the single mechanical components are produced on most modern machine tools and machining centres (kept continuously at the latest state of the art) – the assembly of such complex mechanical groups will always require skilled labour and an experienced „touch“ which a machine – regardless of its number of axes or perfection – can never have.

There is always a certain intuition necessary, acquired in years of practice, to perceive and feel the slightest irregularities, for instance in the noise, the turning pattern, the backlash of the bearings, the warming up, and the smooth running of the machine etc. We know what we are doing when, in the final assembly shop, one foreman oversees only twelve men, who are skilled craftsmen in their own right, most of them trained in our apprentice shop of good reputation, and sought after also by other factories in the region because of their excellent proficiency.

It goes without saying that such a performance of men and machine has its price, and that the turning machines here introduced cannot be cheap (for which we are reproached at times by people not fully aware of the circumstances). Be this as it may, in order to keep the price reasonable, to offer machines of a capacity, precision and quality for the benefit of everybody, we build them in series to the greatest extent along Henry Ford's I line with his famous Tin Lizzy which, he said, can be supplied in any colour as long as it is black. We, in turn, supply the „package“ machines D 420, D 480, and D 530 (the numerals stand for the maximum swing) with any features, as long as you accept them as we pre-selected and determined for you. You may rest assured that these features have been optimized to the best of our knowledge and believe so that you will get a turning machines as universal and perfect as ever desirable. This is a fact.

We repeat a policy followed long ago quite successfully, as early as the year 1927, with the legendary VDF standard lathe. This was a genuine lathe „for the people“, and the lathes of the series D are popular lathes as well, take our word for it. Look at the following pages, particularly pages 13 and 14, enumerating the various equipment available. (Some of the illustrations show options requiring an extra price).

The „smallest” VDF lathe – in full view. A „jewel” of classical machine tool engineering. Also available in toolroom accuracy.

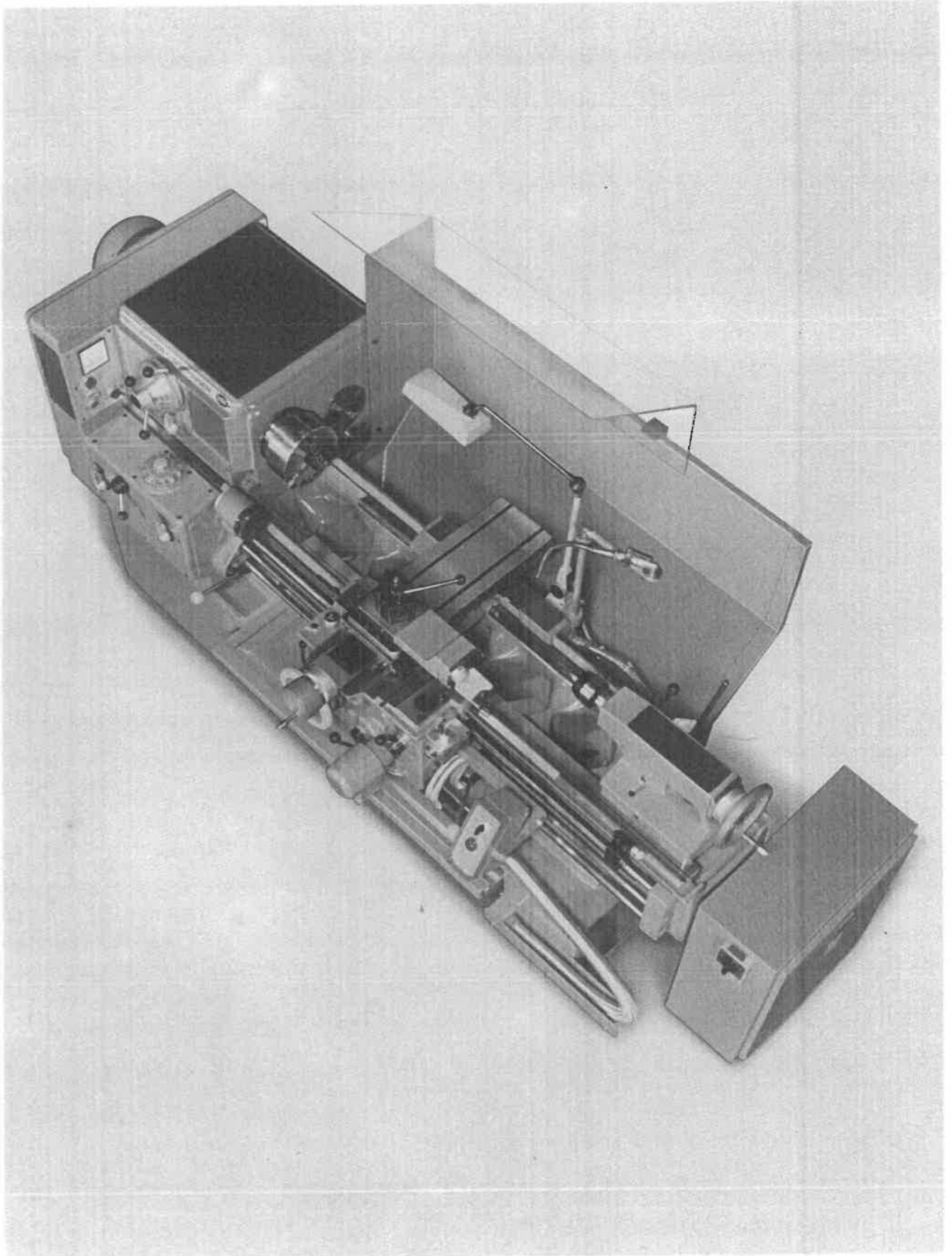

**D 420, D 480,
D 530:
„package” machi-
nes**

**with everything
appropriate for
a lathe.**

**All inclusive
at a remarkably
reasonable price.**

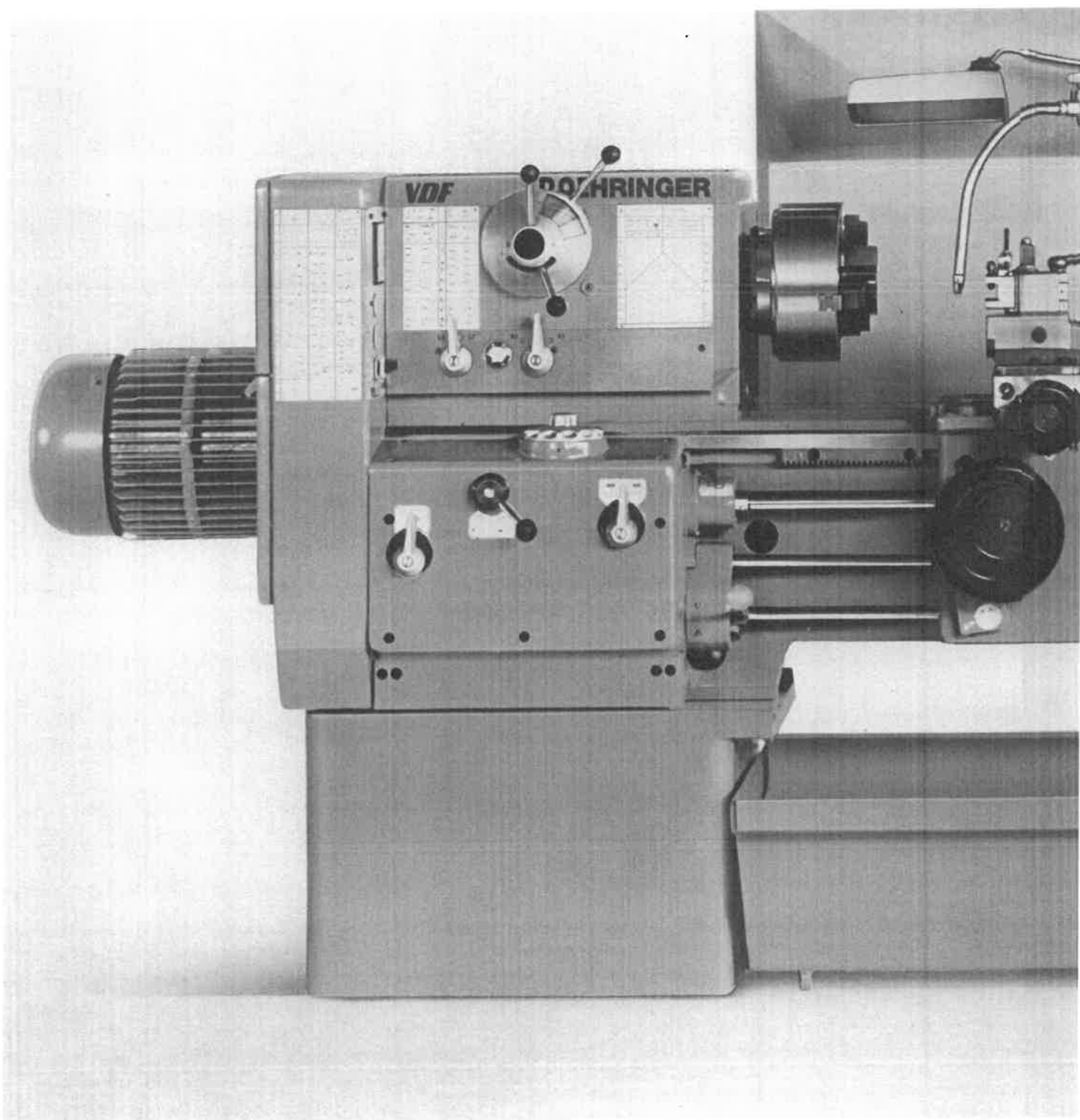

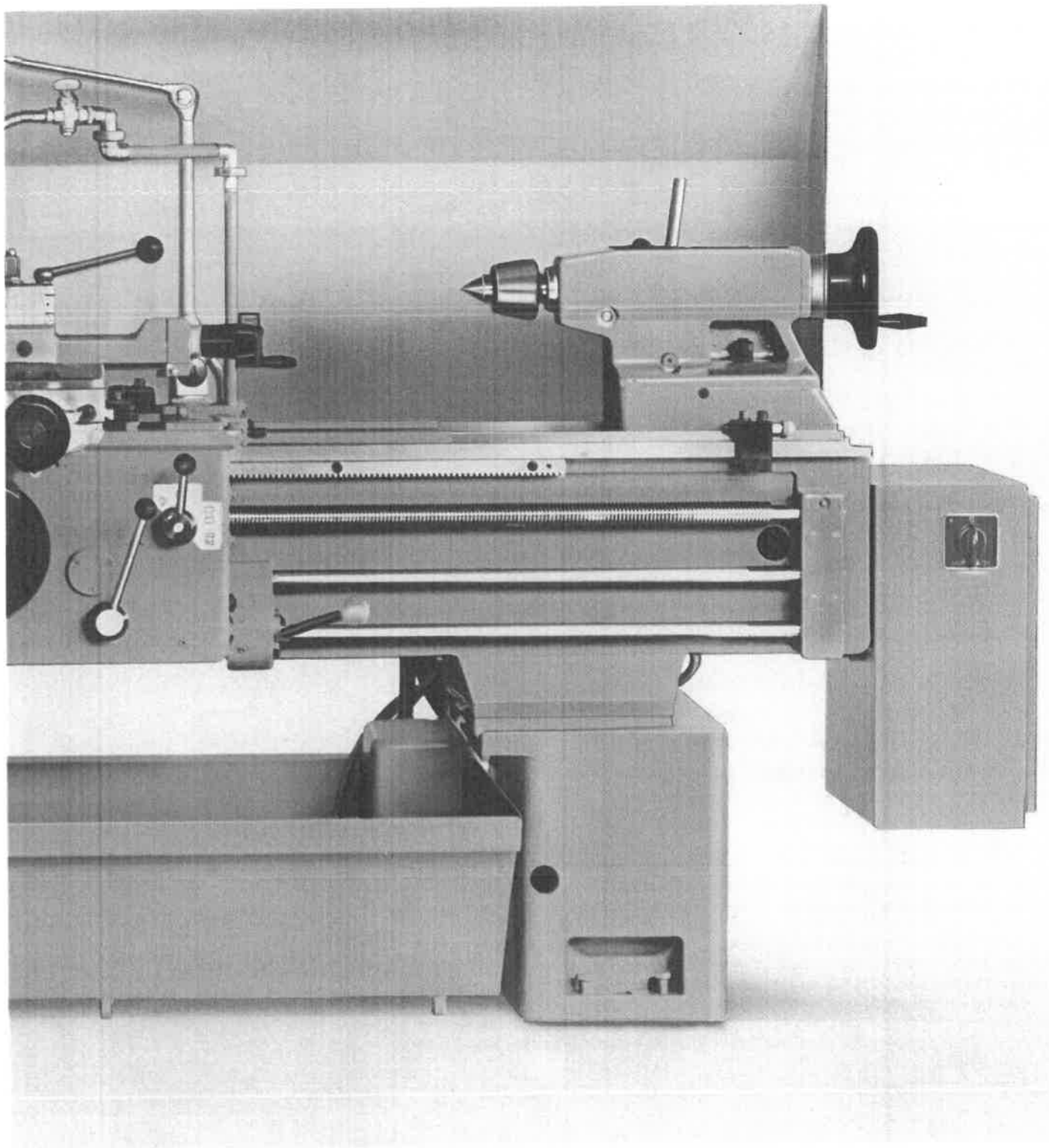

**Series D, models
42 D and 48 D:
for you to choose
the extras you**

**need (or do not
want). A basic con-
cept plus – or minus
various options.**

**Special equipment
on request.**

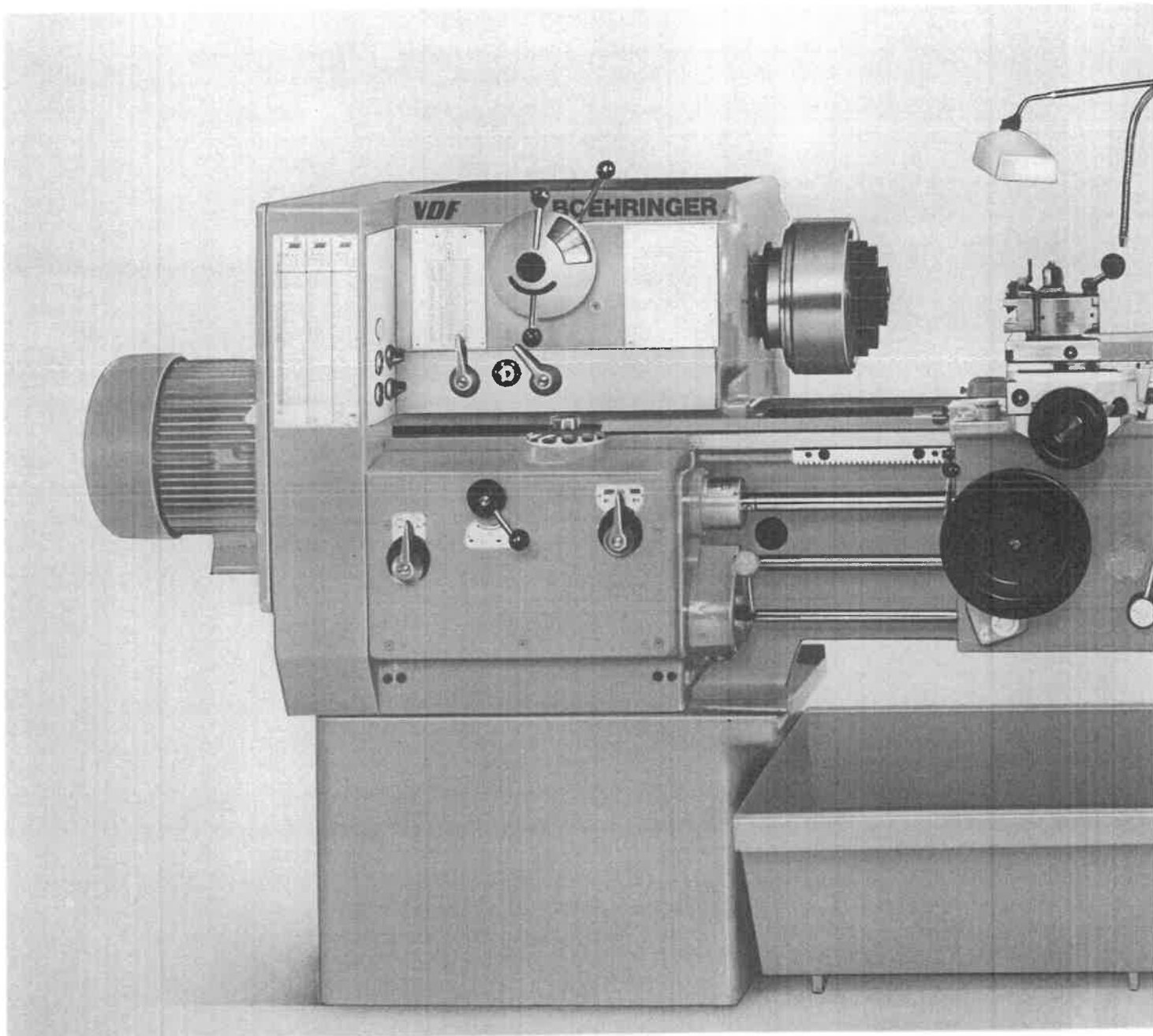

③ The series D – consistent with the time-honoured VDF policy – can be equipped with very special features (if at all possible from the technical point of view, and reasonable regarding the price) in order to comply with customers' wishes. These machines are the models 42 D and 48 D (see Fig. ③), with many options plus, plus, plus, or minus... „as you like it". You, the customer, are the one to decide what you want.

In most of the cases we can resort to the VDF building block assortment which is quite comprehensive. Even requirements a bit „out of the way" can be fulfilled (since we have done it before). If, quite unexpectedly, there should be some difficulties, we certainly shall live up to our good reputation and accepted tradition by discussing with you the hows, and whys and



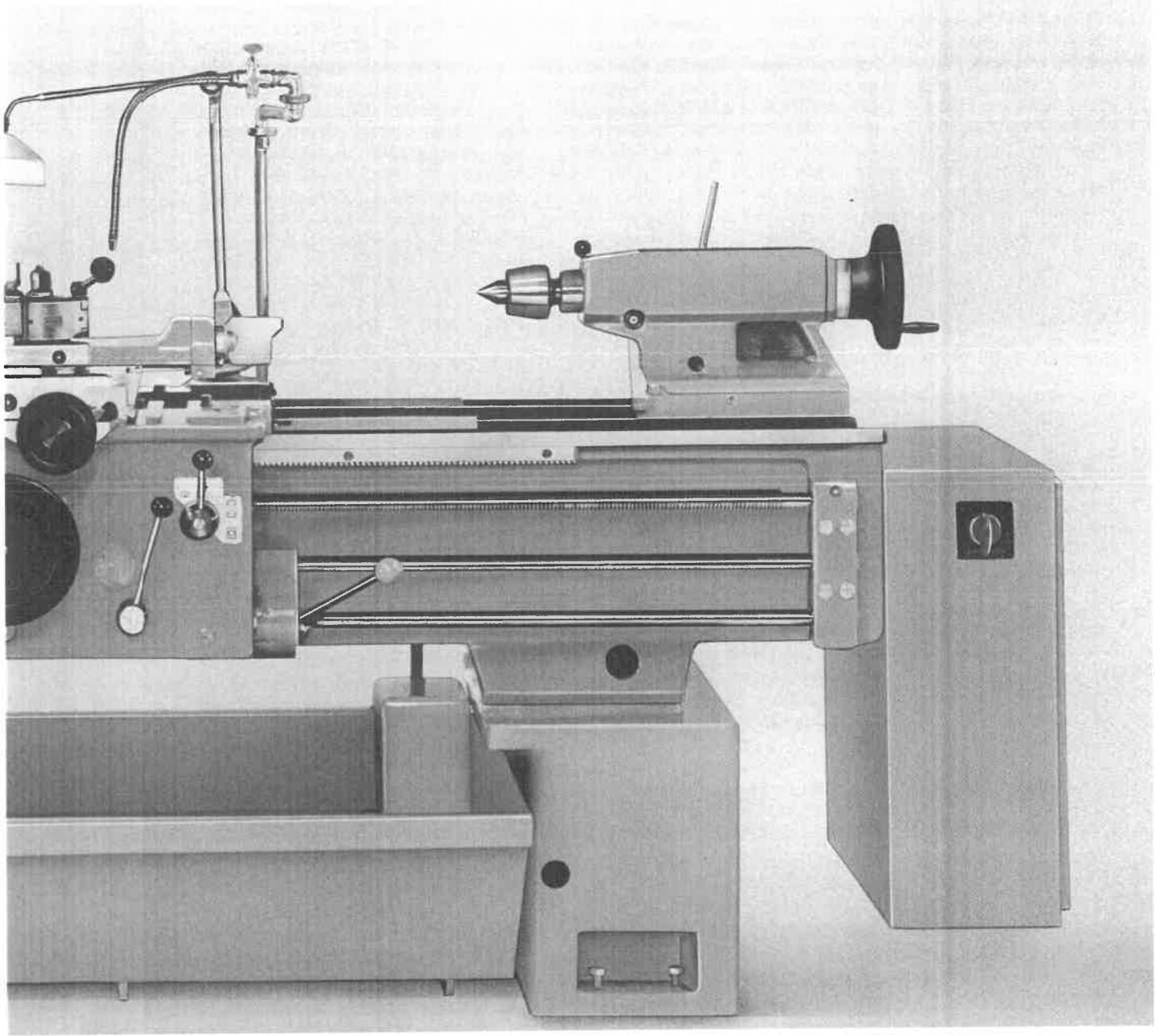

⑤

whens to the last detail. It is quite understandable that such special efforts have their price but still, we have „all that money can buy” or almost everything. Regardless of our technical ambitions and perfectionism, we have to think economically – for the sake of your and our pocketbook.

What we have (and what we have not) is summarized on pages 13 and 14, to offer a clean, „tidy” and clearly arranged working place, designed to answer also requirements of ergonomics (④ and ⑤), to make it more „beautiful”, to improve, specialise, automate the application of the machines. If you want more (or less), talk it over with your and our specialists. Your questions will be fully answered, „no strings attached”, of course.

The bed – the backbone of a lathe and contributive to its smooth running – is a very heavy, torsion-free, hollow beam of closed box-type cross section, formed by thick walls, with X-ribbing and inclined chutes for a free fall of chips, preventing a warming-up of the bed and heat expansion which could negatively influence the turning results. Sturdy legs without flanges assure the machine's firm stand and contribute to a direct dissipation of the cutting forces into the foundation. A big, separate coolant and chip tray sits between the legs. An exchange of heat between bed and tray is impossible.

The bed is made of high quality Meehanite cast iron of a very dense structure and good damping properties to absorb vibrations. Incidentally, the beds are cast in our own foundry, one of the best equipped in its category and in this region (and, therefore, well in demand also by our „colleagues“).

Two types of guideways are used on the bed: Vees and flatways. One Vee and the flatway for tailstock, fixed steady rests and similar, and the two outer Vees – a typical VDF concept on horizontal beds – for the carriage.

This guideway design is of particular advantage if rather heavy tool carriers and tools are mounted on the carriage remote from the turning centre line, for instance: a heavy boring rest and boring bars or similar. The guiding surfaces are amply dimensioned for a lifelong accuracy (as expected as a matter of course from a VDF turning machine), and to obtain very low local surface pressures. The wear from sliding friction is negligible. We decided on mating grey cast iron with hardened cast iron. All carrying surfaces are carefully induction hardened and precision ground. This ensures short positioning distances, an excellent repeatability, and a minimum of lost motions on the one hand, as well as a heavy chip removal capacity when roughing, and an extremely good surface quality when finishing.

A very sturdy and rather long cross slide takes easily two tool carriers. The ratio of length to width is very favourable. Backlash is adjustable by tapered gibs.

All spindles are carefully protected and provided with large, easily legible graduated collars. A drum with scales on the handwheel shaft facilitates longitudinal turning operations.

The feed directions can be reversed via a spur gearing in the apron.

In order to avoid damages when working against a positive stop, a drop worm automatically cuts out both transverse and longitudinal movements, and protects the machine from overload. – The leadscrew has a trapezoidal thread and metric lead, with half nut to transmit the movements to the carriage. All shafts in the apron are carried in two bearings. Longitudinal and transverse movements, as well as the half nut, are controlled by only one lever. – On request, we supply a motorised rapid traverse, (see Fig. ①) which can be quickly engaged and disengaged by a lever.

The headstock – reassuringly sturdy and massive – is an assembly fully proved in thousands of applications from the VDF building block system for universal turning machines. It is a one-piece casting sitting securely with a wide base on the bed, and shows a neutral thermal and dynamical behaviour, as one of the pre-requisites for exemplary smooth running, high rigidity and excellent accuracies, under all working conditions. Since all guideways are machined simultaneously, headstock, carriage and tailstock are accurately aligned.

At a progression ratio of 1.25 and a speed range of $B = 200:1$, a total of 24 speeds are available through gears. The uni-directional (A.C.) motor is flange mounted, and well balanced. Since the motor runs continuously in one direction and is never disengaged during operations, reversal of spindle rotation and spindle stop is obtained through two mechanical clutches on the input shaft. The main spindle is braked by an electro-mechanical brake, requiring no maintenance. Its heat is dissipated directly to the outside. The speeds are selected at a three-lever visual control. The spur gears are hardened and ground and all rotating parts are statically and dynamically balanced for a noiseless and smooth running at each spindle speed.

As expected on an engine lathe, the main spindle is amply dimensioned with a bore of 62 mm. Special attention has been paid to the bearing arrangement. We use high-precision anti-friction bearings. The front bearing, diameter 100 mm, sits directly behind the spindle flange to keep the leverage from the cutting forces as low as possible. The obvious advantage of such an arrangement: high rigidity when taking heavy cuts and a good carrying capacity even at maximum spindle speeds.

All rotating parts and the bearings in the headstock (and also in the feed gearbox and apron) are automatically lubricated by a continuous circulation system.

The thread cutting gearbox with the oil container for the lubrication is accommodated in a separate casting, affixed to the headstock. When cutting metric and imperial threads, no change of gears is required. For module and D.P. threads, only two gears have to be exchanged. On request, a dividing attachment is available for multi-start threads (see page 9).

The feed gearbox consists of a 10-step basic and a 4-step multiplying gearing, plus a change-over gearing each for metric and inch threading operations, and for work with leadscrew or feed rod. A total of 56 each standardised feed values in a progression ratio of 1.12 are available for longitudinal and transverse feeds. All standard DIN and USA threads can be selected directly including $11\frac{1}{2}$, 13, 26 and 27 tpi., and also the feed values via a quick-action control (see page 9). The operator can double or half the set feed value by simply turning a dial – the original setting is maintained.

Consistent with the basic concept of these machines, the tailstock again is designed for extreme rigidity. It is a massive casting with a wide base on the bed – at an optimum ratio of width to centre height, and guided in a flat and a Vee way. After releasing the single-lever clamping, it can be easily moved on the bed. An additional clamping holds it firmly on the bed for heavy cuts. The quill locking acts from below to rule out diameter or cylindrical errors. The top of the tailstock can be adjusted parallel to the centre line (e.g. for turning slight tapers).

All commercially available manual chucking fixtures may be used. The tooling systems are identical for all machines except for different sizes, (see page 10). We supply the time-tested Multifix, or a Boehringer quick-change toolpost, and a four-way-toolpost with radial serration which can be released, indexed, and clamped by only one lever (this is why we speak of a single-hand operation). There is also a heavy boring rest with boring bar for deep bores and heavy internal cuts and, of course, the usual plain (heart-shaped) toolpost, as well as a tool block in the rear of the long cross slide, etc.

All in all, the machines represent an efficient working place

with many safety features for man and machine.

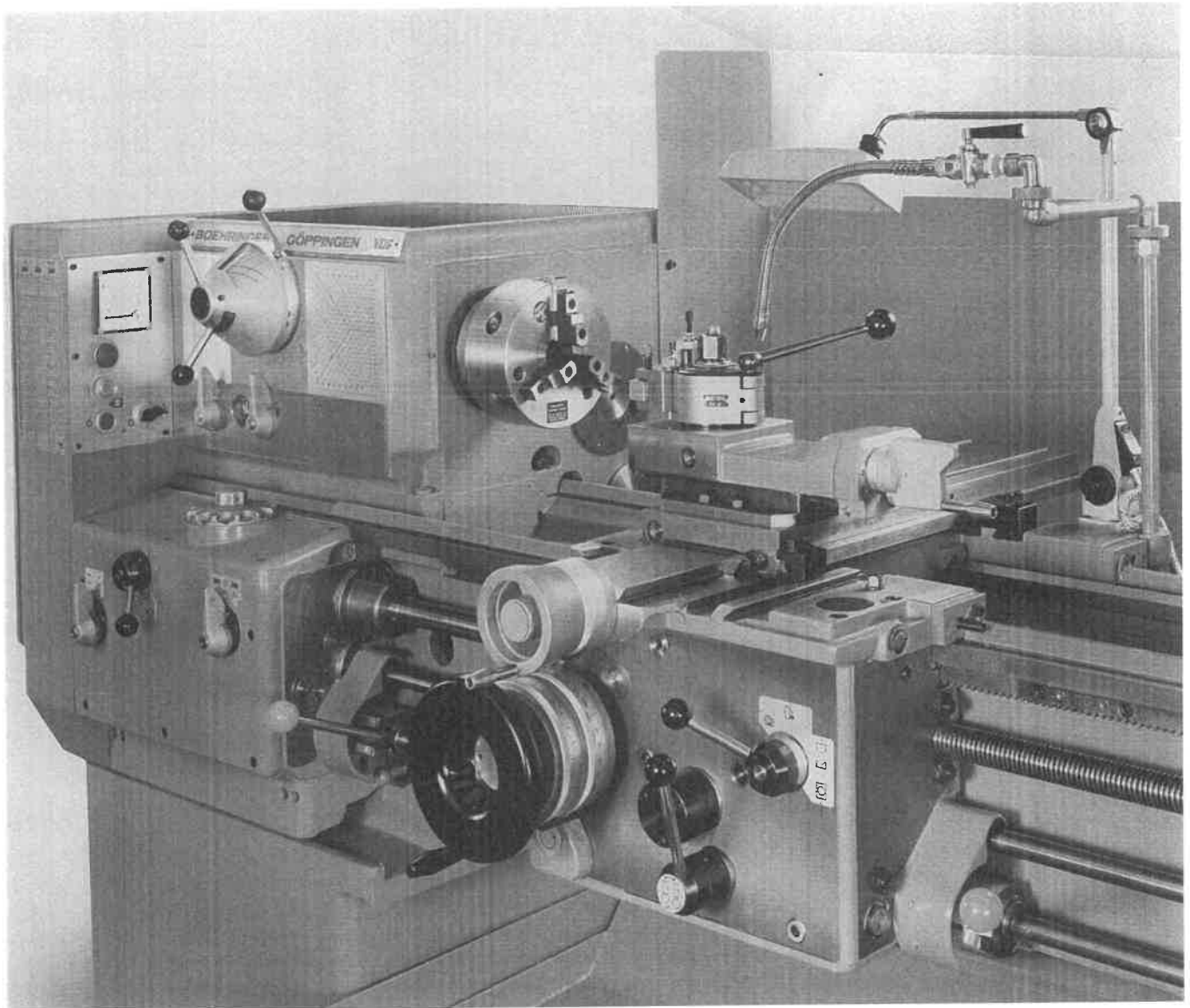

⑥ One of our primary objectives in designing the D machines was to offer an orderly, humane and safe working place, and free access to tools and workpiece, including easy operation.

All 24 speeds can be selected directly at a three-lever visual control. (Two small levers select the use of the leadscrew or the feed rod). The feed values again can be set directly on a quick-action control unit. There are also two synchronised remote control levers for „ON-OFF„.

The apron is operated from three levers, one of which controlling longitudinal and transverse movements and the half nut. Automatically responding stops assure safety for man and machine.

A low-noise VDF headstock, fully proved in hundreds of applications.

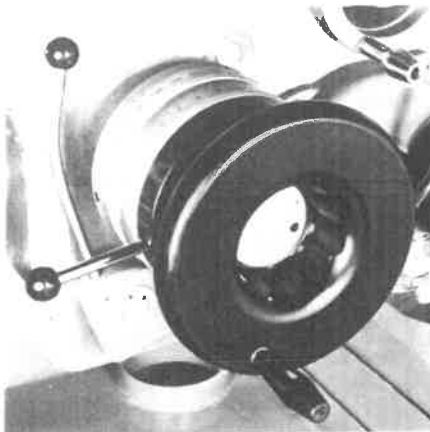

⑦

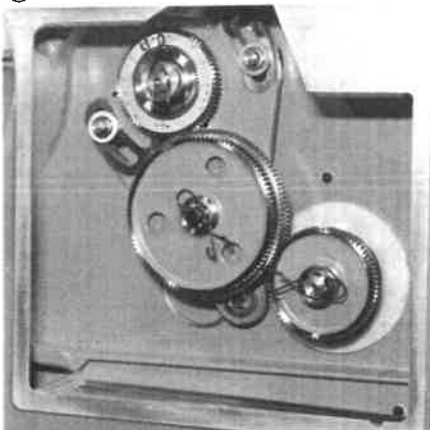

⑧

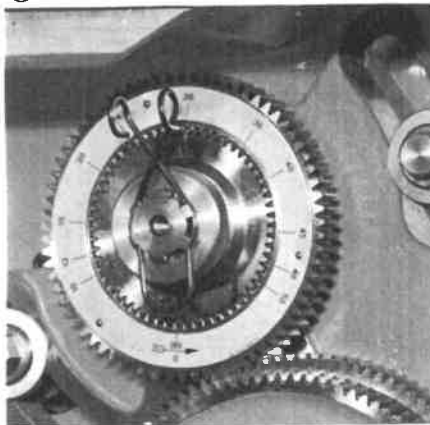

⑨

⑦ Vertical lever: change-over gearing for longitudinal and transverse feeds. Horizontal lever: motorised rapid traverse, longitudinal*.

⑧ Module and D.P. threads* require interchange of two change gears, no adjustment of quadrant necessary. No hand tools required.

Metric and inch threads require no change gear re-setting.

⑨ Multi-start threads are set a dividing attachment on main shaft for a simple and accurate dividing of 2-, 3-, 4-, 5- and 6-start threads*.

* Option

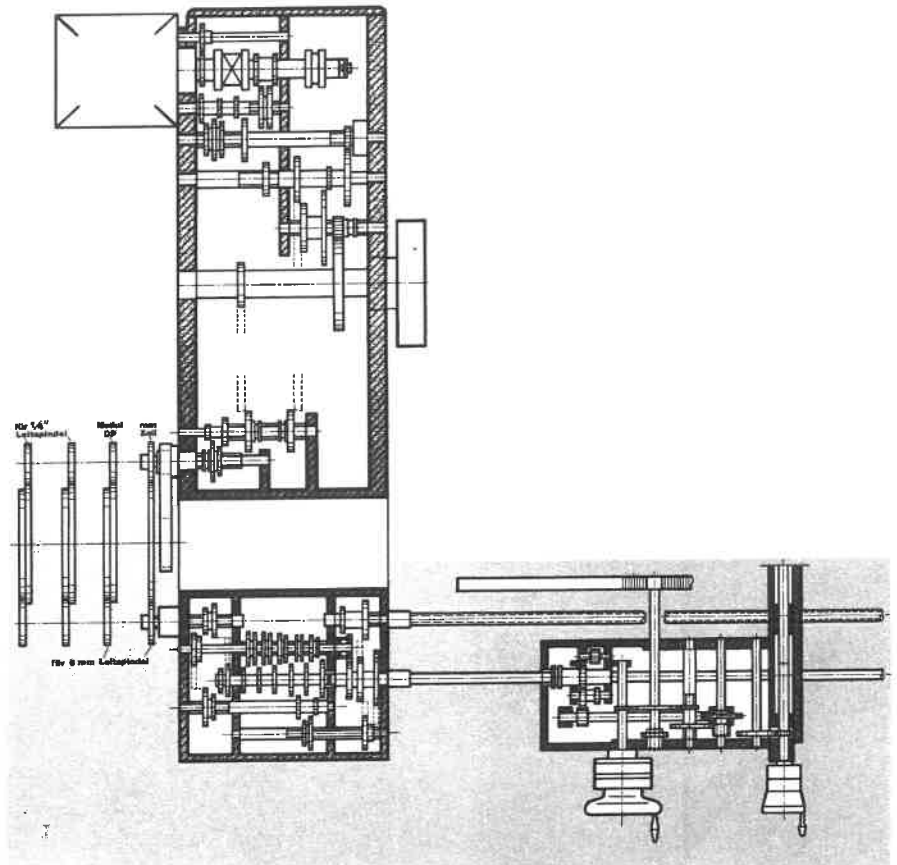

⑩

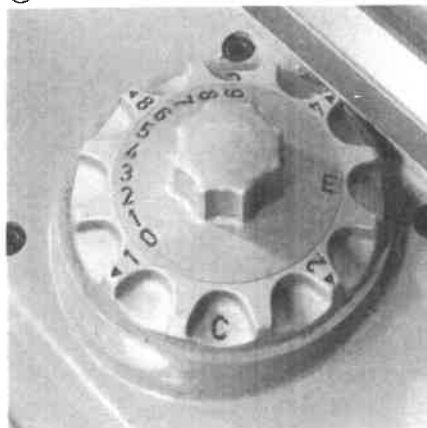

⑪

⑩ Schematic representation of headstock, feed gearbox and apron.

⑪ 32 each longitudinal and transverse feeds as well as the thread leads can be set at the two dials of the quick-action control, according to the easily understood feed/thread cutting plate. Selection and setting of the combinations can be read and verified by the operator at a glance. If the workpiece is finish machined in the same setting after roughing operations, the outer ring can be turned by 90° to have a halved feedrate for finishing (or a fourth or eighth of the set roughing feed).

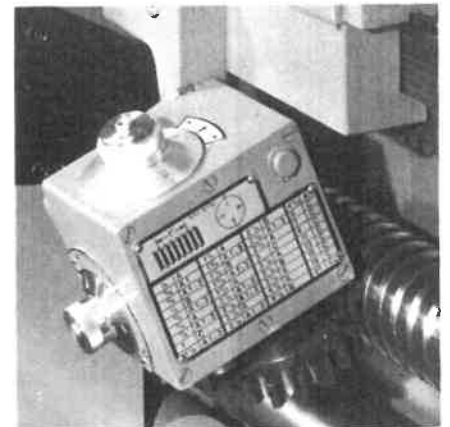

⑫

Turn the dial back to original setting, and the feedrate for roughing operations is effective again.

⑫ The thread cutting dial* facilitates threading operations since no reversal of rotating direction is necessary, and the start of the thread for the next pass is automatically found after the carriage has been returned. Also available for the models 42 D/48 D, if equipped with inch pitch leadscrew, for cutting inch threads.

A rigid bed, an optimised main spindle

and a universal tooling system.

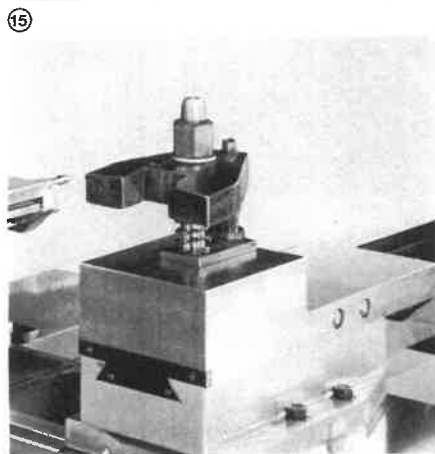
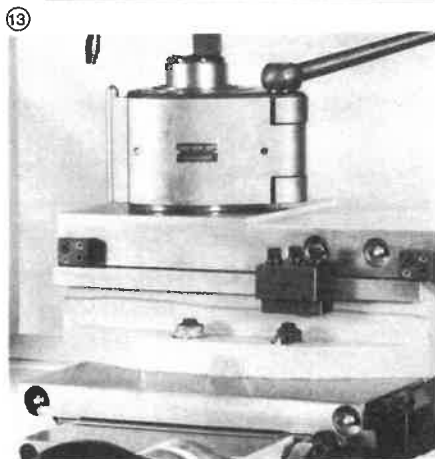
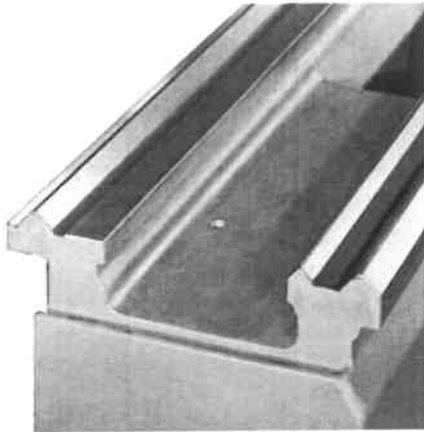

⑬ A heavy and rigid bed with inner Vee and flatway for guiding the tailstock and fixed steadies, and two outer Vees to guide the carriage.

⑭ The main spindle, carried at both ends in high-precision bearings. The spindle diameter in the front bearing is 100 mm.

⑮⑯ Compound rest with power feed* for taper turning (on the 48 D and D 530). Power feed is identical with the set transverse feed. Movement of the compound rest is controlled by an adjustable stop.

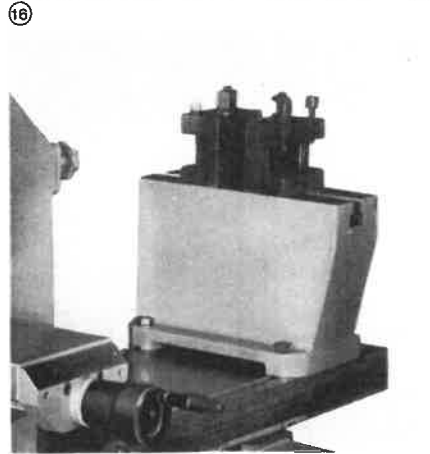
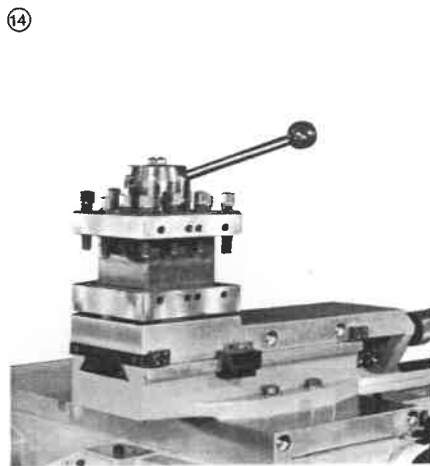

⑰ A Boehringer quick-change toolpost*.

⑱ A plain (heart-shaped) toolpost* (for models 42 D/48 D) for tools of a large cross section of the shank, or for clamping grinding and milling attachments, or similar.

⑲ Alternatively, a fourway toolpost* (with radial serration). Only one lever for releasing, indexing and re-clamping.

⑳ A Multifix toolpost (see also Fig. ⑮ and ⑲) is standard for the models D 420/D 480/D 530, and can also be used on the models 42 D/48 D.

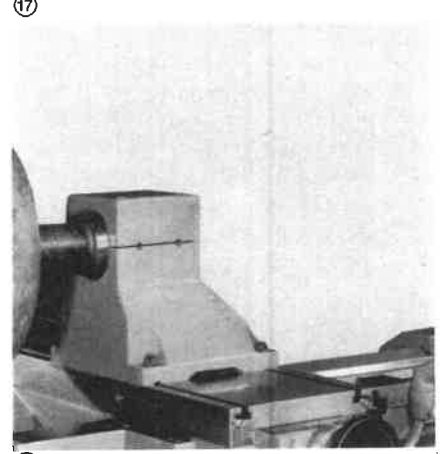
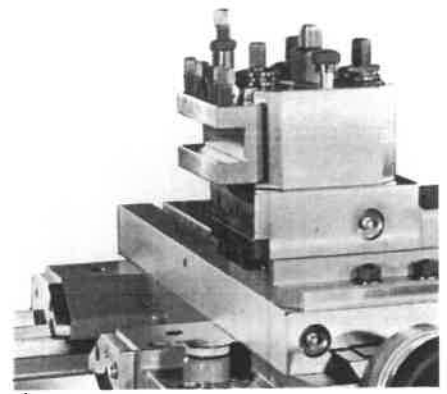

⑲ A tool block* in the rear of the long cross slide, for compound turning (simultaneously in front of and behind turning centre line) e.g. when turning long shafts or for recessing in a pulling cut.

⑳ Boring rest*, in addition to the compound rest with a very rigid boring bar for deep bores, and heavy roughing cuts, also for finishing cuts to obtain a surface finish much better than usual on machines of similar size.

With many practical options (against extra price).

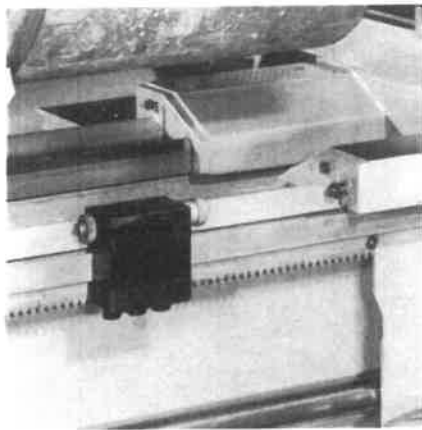

⑳

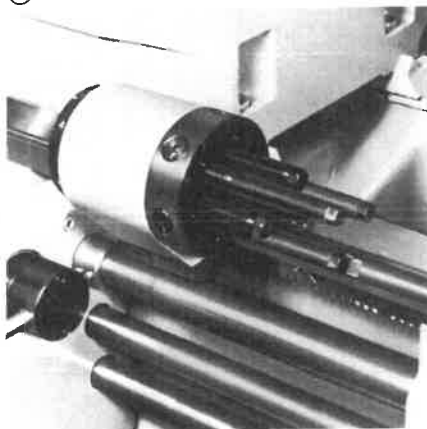

㉑



㉒

㉒ Length stop to be positioned in any place on the bed, fine adjustment by vernier screw.

㉑ Sixtuple length stop drum*. Six length positions can be quickly and accurately set. The drum is rotated by hand for positioning the required stop.

㉒ The display for an electronic position measuring system* for transverse (X axis) and longitudinal (Z axis = Y on the display) movements. Depending on make and design, desired end positions can be pre-selected. The display can be zeroed in any position, the direction for measuring, and the measuring system (metric or inch) can be selected freely.

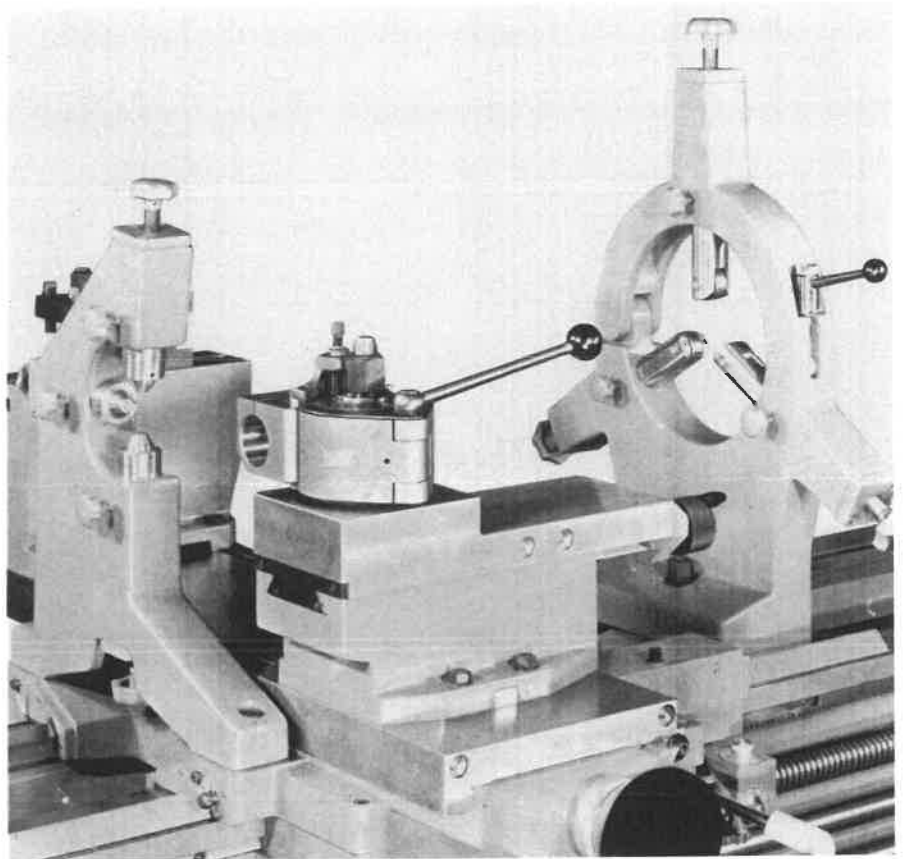

㉓

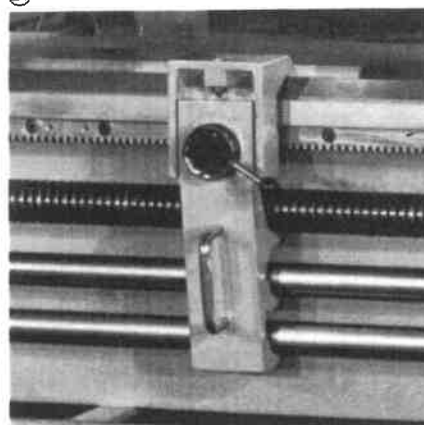

㉔

㉓ Travelling (Fig. ㉓ l.h.) and fixed steadies* (Fig. ㉓ r.h.). The travelling steady supports the workpiece immediately in front of or behind the tool. With pads or rollers to guide the shaft. For capacities see page 16, table 3.

㉔ Shaft supports for leadscrew, feed rod and remote-control shaft, on machines with turning lengths of 2000 mm and up, to be placed next to the apron.

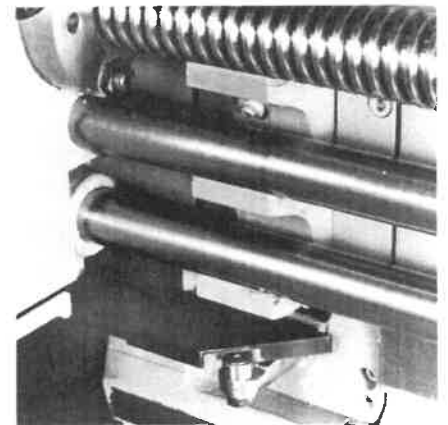

㉕

㉕ Advancing and retracting shaft supports as an alternative (* for 42 D/48 D). While the apron passes, the support is automatically retracted. The number of shaft supports recommended for different turning lengths can be taken from table 4 on page 16.

* Option

**For universal use
in small and large
workshops. With
copying equipment.**

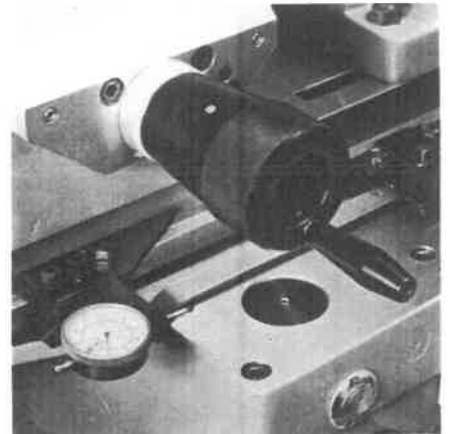
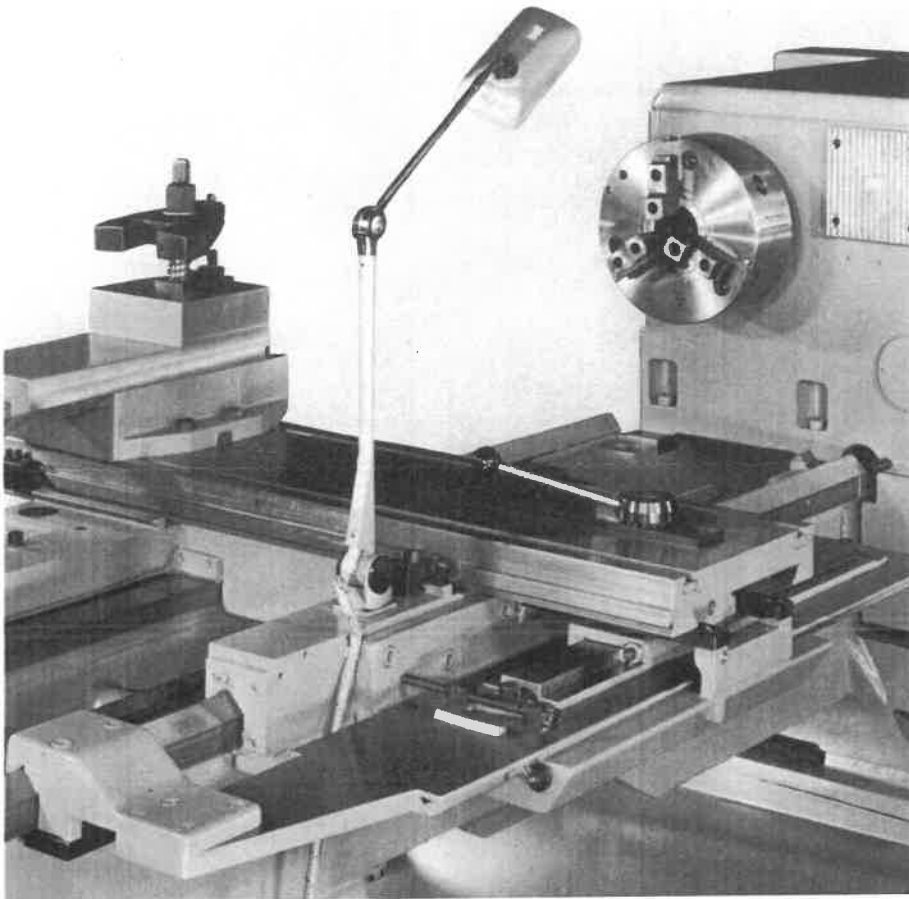

26

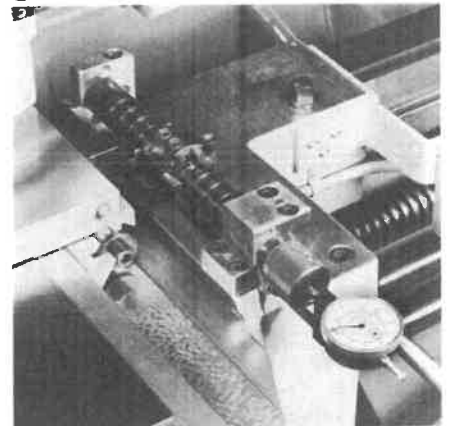

29

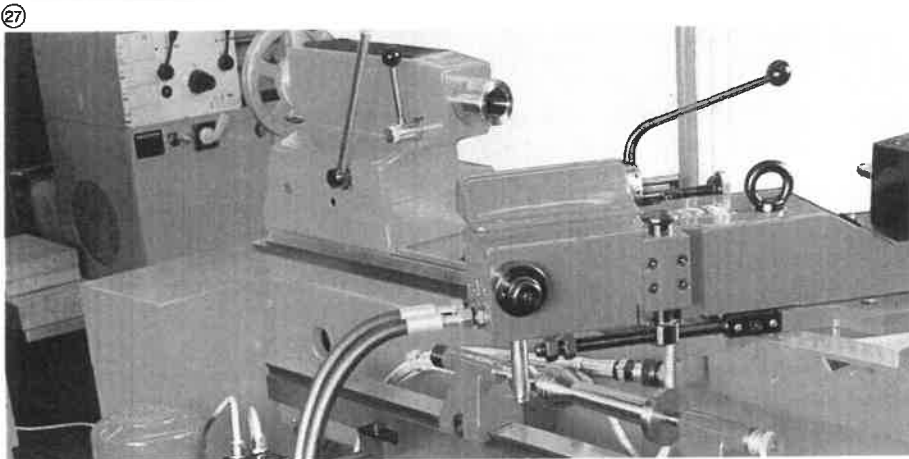

27

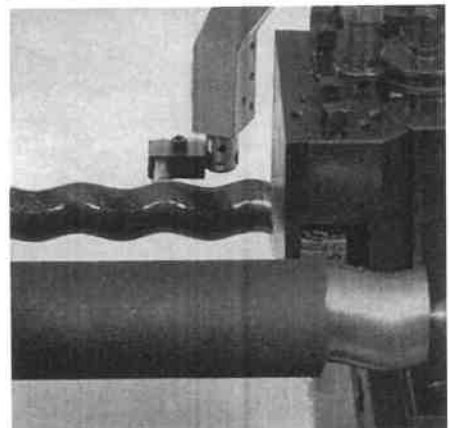

31

27 Taper bar* for tapers of up to 400 mm length and 10° angle. Ascending and descending tapers can be machined in feed direction. The taper angle can be set at a screw and read from a graduated scale and vernier. Re-setting from cylindrical to taper turning (and vice versa) is very easy and quick.

28 Cross stop* with dial indicator for an exact control of the stop position.

29 Quadruple cross stop drum* with dial indicator (for 42 D/48 D). Four different diameters can be set and approached repeatedly.

31 Copying units of various makes can be used*.

30 Copying unit for longitudinal and transverse operations, with master shaft carrier, and template holder for a flat template as well as multi-cut attachment for 3 roughing, 1 copying and 1 finish copying cuts.

31 Workpiece, master shaft and tracer for out-of-round copying (on 48 D only). In many cases the only machining method for similar workpieces.

**Basic design,
standard equipment
(●) and options (○)
for the series D
machines.**

Type		D420	D480	D530	42D	48D
Bed:	Hardened and ground guideways	●	●	●	●	●
	Chip and coolant tray(s), separate.....	2 ●	●	●	●	●
	Shaft support(s) for turning lengths of 2000 mm and up	25 ●	●	●	●	●
	alternatively: automatically advancing and retracting shaft supports ..	26 —	—	—	○	○
	Chip protection wall (not possible if copying unit or taper bar is used) Increased accuracy to DIN 8605 (for turning lengths up to 1500 mm)	6 ●	●	●	○	○
Head-stock:	Gears hardened and ground	●	●	●	●	●
	Electro-mechanical main spindle brake	●	●	●	●	●
	Circulating lubrication	●	●	●	●	●
	Three-level visual control of speeds.....	3 ●	●	●	●	●
	Spindle nose with centring taper and Camlock 8 D1 ASA B 5.9.....	—	—	—	○	○
	Taper sleeve and dead centre MT 5..... Reduced noise level.....	○	○	○	○	○
Feed gear-boxes:	Additional remote control lever for spindle START/STOP at feed gearbox	6 ●	●	●	●	●
	153 directly selectable leads for each type of thread (also 11½, 13, 26, 27 tpi).....	●	●	●	●	●
Lead-screw:	Increased pitch accuracy of leadscrew.....	—	—	—	○	○
	Leadscrew with ¼" pitch	—	—	—	○	○
	Additional change gears for 53 thread leads module 0.05... 28	10 ○	○	○	○	○
	114 thread leads D.P. 560... 1 tpπ"	10 ○	○	○	○	○
	Dividing attachment for multi-start threads	9 ○	○	○	○	○
	Thread dial indicator for metric pitch leadscrew	12 ○	○	○	○	○
Thread dial indicator for inch pitch leadscrew	12 —	—	—	○	○	
Apron:	Reversal gearing for feed movements (longitudinal and transverse)	6 ●	●	●	●	●
	Length indication via graduated collars on handwheel shaft.....	6 ●	●	●	●	●
	Overload safety cut-out (to stop carriage reliably when contacting a positive stop)	7 ●	●	●	●	●
Longitudinal rapid traverse	7 ○	○	○	○	○	
Carriage:	Long cross slide.....	15 ●	●	●	●	●
	Multifix quick-change toolpost, size B	16 ○	○	○	○	○
	Fourway toolpost with radial serration (single-lever operation).....	18 —	—	—	○	○
	Plain (heart-shaped) toolpost	17 —	—	—	○	○
	Boehring quick-change toolpost size 400	17 —	—	—	○	○
	other toolposts	17 —	—	—	○	○
	Rear tool block with 2 toolholders	19 ○	○	○	○	○
	Boring rest for long boring bars (locating dia. 65 mm)	20 ○	○	○	○	○
	Taper bar for 400 mm taper length, adjustable ± 10°	27 —	—	○	○	○
	Power feed in compound rest for 180 mm traverse (no taper bar possible).....	16 —	—	○	—	○
	Copying unit, make SAUTER or	30 ○	○	○	○	○
	make Boehring HYDROCOP	—	—	—	○	○
	for out-of-round copying.....	31 —	—	—	○	○
	Cross stop with dial indicator	28 ○	○	○	○	○
	Quadruple cross stop drum (not possible with power feed).....	29 —	—	—	○	○
Sixtuple length stop drum for quick positioning of stops.....	22 ○	○	○	○	○	
Electronic position measuring system, for longitudinal and transverse axes.....	23 ○	○	○	○	○	
Splash guard, adjustable, travelling with carriage.....	○	○	○	○	○	

Table 1

Changes in technical specifications reserved.

- included in basic price
- options against extra price
- not possible

**Basic design,
standard equipment
(●) and options (○)
for the series D
machines.**

Type	Fig	D420	D480	D530	42 D	48 D
Tailstock: Quick-action clamping and additional clamping for heavy cuts and/or heavy workpieces.....		●	●	●	●	●
Laterally adjustable top.....		●	●	●	●	●
Live centre MT 5.....		●	●	●	●	●
Graduated collar for quill adjustment, metric.....		—	—	○	○	○
Hydraulically operated quill.....		—	—	○	○	○
Electrics: Complete drive (flange-mounted motor).....	6	●	●	●	●	●
Power meter in operating panel.....		●	●	●	●	●
Fluorescent lamp, splash proof.....		●	●	●	●	●
Electrical pump for coolant supply.....		●	●	●	●	●
Painting: Two-component paint on synthetic resin basis RAL 6011 (green).....		○	○	○	○	○
other paints to RAL, preferably RAL 1007 (chrome-yellow).....		○	○	○	○	○
Standard Accessories: Complete coolant supply with tray(s), piping and hoses.....	21	●	●	●	●	●
1 length stop, 1 cross stop.....		●	●	●	●	●
Speed and thread-cutting plate.....		●	●	●	●	●
2 operating manuals.....		●	●	●	●	●
1 spare parts catalogue.....		●	●	●	●	●
1 grease gun, 1 set of spanners.....		●	●	●	●	●
Others: Chucking Fixtures: Independent 4-jaw chucks, face plates, manually operated 3-and 4-jaw chucks, collet chucks, driver plates, back plates.....		○	○	○	○	○
Power-operated chucks, solid, partial and full-length hollow clamping.....		○	○	○	○	○
Steadies: fixed and travelling, with pads, rollers or pads and rollers...		○	○	○	○	○

Table 1

Changes in technical specifications reserved.

- included in basic price
- options against extra price
- not possible

And finally: if somebody should find a D 420, D 480 or D 530 too small

for his needs, VDF has universal turning machines in 16 bigger sizes:

**5 from Boehringe
11 from Wohlenberg.**

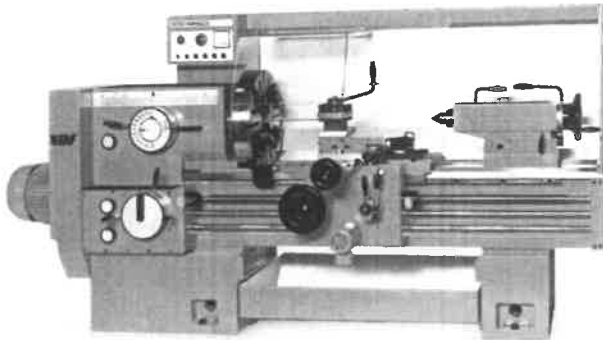

③② Series DM 550/DM 640

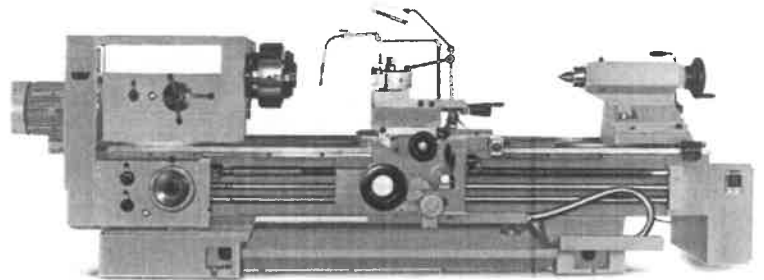

③③ Series E 560/M 670/V 800

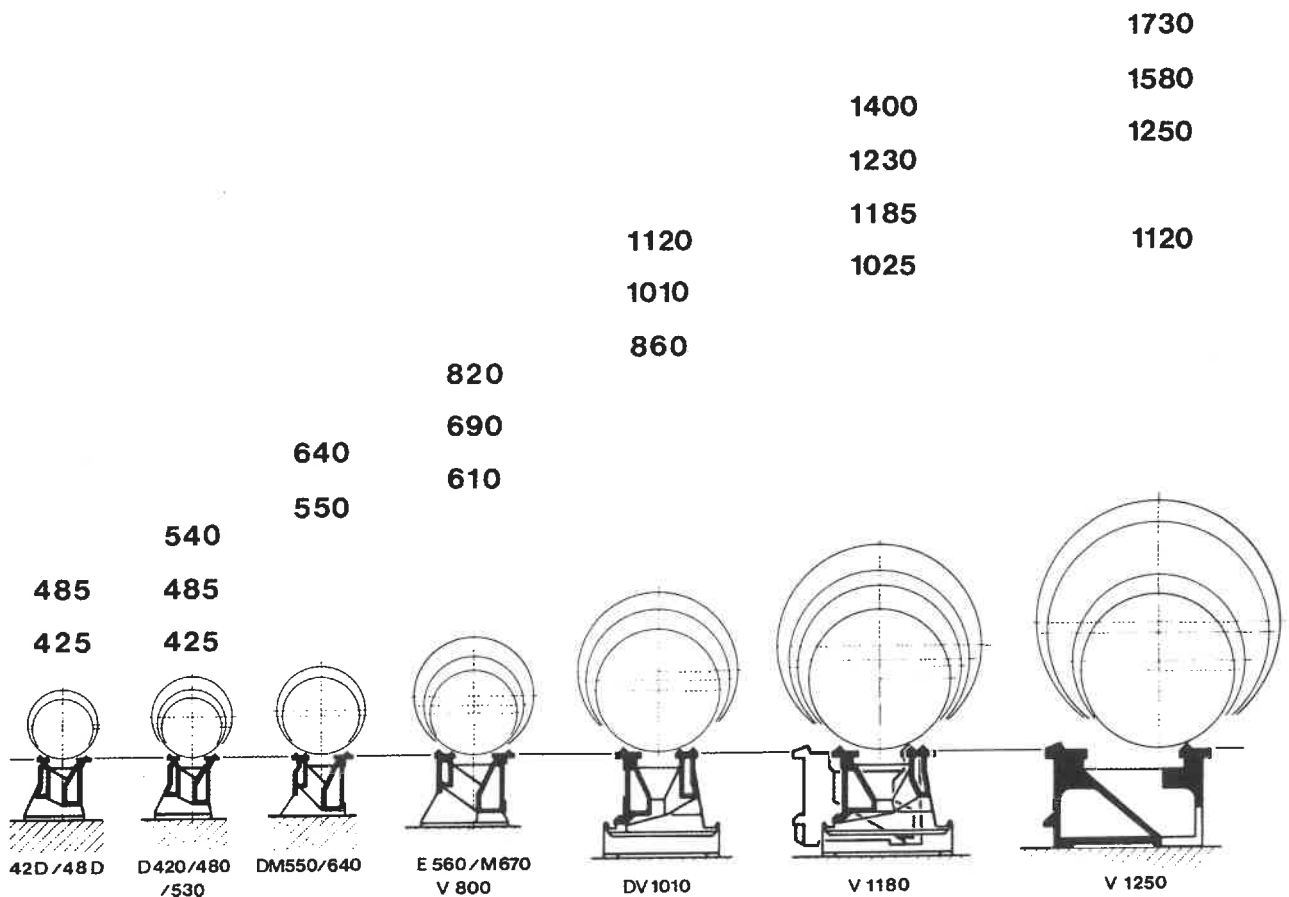

③④ The VDF Program: from 425 up to 1730 mm swing over bed

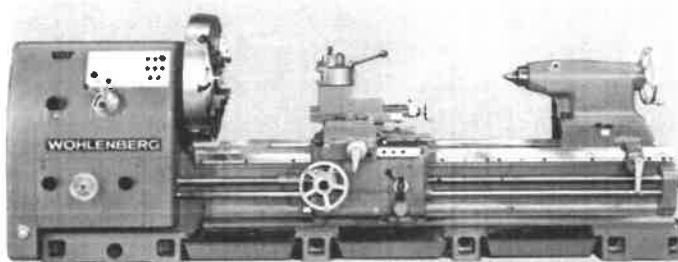

③⑤ Series DV 1010

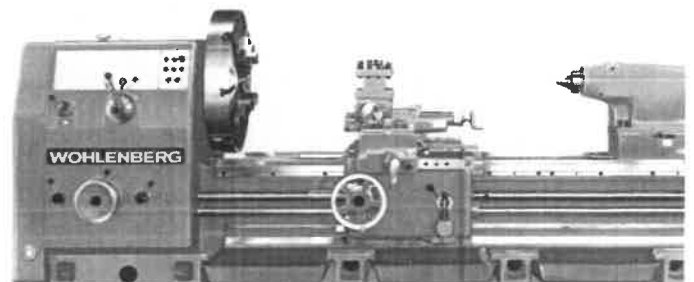

③⑥ Series V 1180

Dimensions and technical main data.

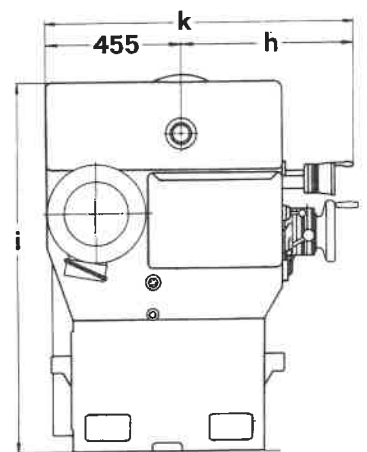
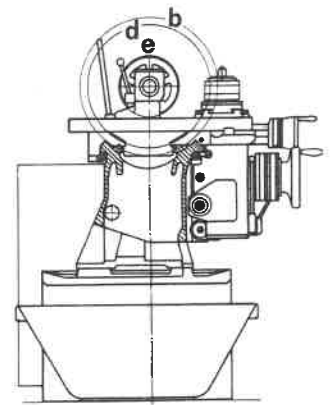
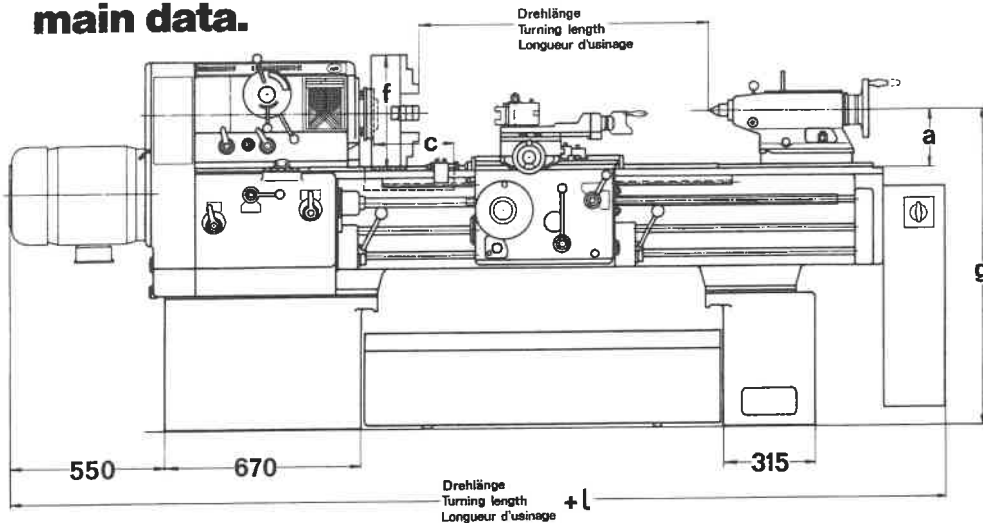

Model	a	b	c	d	e	f	g	h	i	k	l
D 420/42 D	200	470	165	425	205	355	1076	595	1254	1050	2200
D 480/48 D	232	520	165	485	270	450	1108	595	1286	1050	2200
D 530	264	580	155	530	330	500	1140	595	1318	1050	2200

Table 2. Dimensions in mm.

Design	Fixed Steadies				Travelling Steadies		
	No. of quills						
No. of quills	3						
Capacity	10-160	10-200	40-315	120-280	10-100	10-125	25-160
D 420/42 D	x	-	-	x	x	-	-
D 480/48 D	x	-	-	x	-	x	-
D 530	-	x	x	-	-	-	x

Table 3. Available Steadies.

Model	D 420/42 D D 480/48 D		42 D 48 D	
	Turning length mm	1000 1500	2000	3000
Number of shaft carriers	0	1	2	

Table 4. Number of shaft carriers depending on turning length. - Other turning lengths on request.

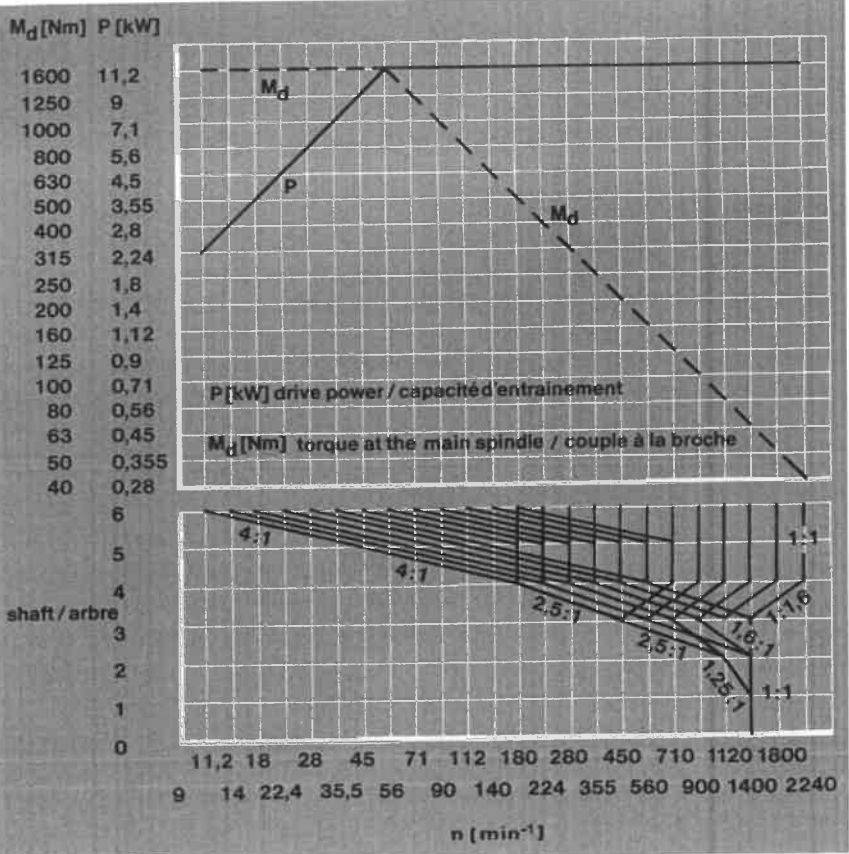

Diagram (at right): Driving power and torque in relation to speed.

Technical Data.

Type	D 420 42 D	D 480 48 D	D 530
------	---------------	---------------	-------

Working range

Height of centres over flatway	mm	a	200	232	264
Swing in gap, max.	mm	b	470	520	580
width of gap in front of spindle nose	mm	c	165	165	155
over bed	mm	d	425	485	530
over carriage	mm	e	205	270	330
Max. permissible O.D. of chucking fixture	mm	f	355	450	500
Width of bed	mm		360		
Tailstock MT of centre	No.		5		
diameter of tailstock quill	mm		70		80
stroke of quill	mm		180		
Carriage	guided length	mm	500		
cross slide	length	mm	630		
	width	mm	210		
	traverse	mm	310		
compound rest	length	mm	350		
	width	mm	140		
	traverse	mm	125		

Main drive

Driving power	kW		11		
Spindle nose to DIN 55022	size		6		8
dia. of spindle in front bearing	mm		100		
dia. of spindle bore	mm		62		
24 speeds through gears	rpm		11.2...2240		
progression ratio	φ		1.25		
Max. torque at main spindle	Nm		1600		
Max. cross section of tool shank to DIN 770	mm		32 x 25		

Feeds and thread leads

Feeds selectable at dial					
32 longitudinal feeds	mm/rev		0.045...1.6		
32 transverse feeds	mm/rev		0.02...0.71		
Feeds total					
56 longitudinal feeds	mm/rev		0.045...25		
56 transverse feeds	mm/rev		0.02...11.2		
Thread leads					
80 metric threads	mm		0.2...112		
114 inch threads	tpi		140...1/4		
53 module threads*	module		0.05...28		
114 diametral pitch threads*	t π "		560...1		
Total leads per type of thread			153		
Leadscrew pitch	mm		6		
diameter	mm		36		

Dimensions

Floor space required width	mm	k	1050		
length = TL plus	mm	l	2200		
For turning lengths see Table 4					

* Option

Changes in technical specifications reserved.

VDF

Boehringer in
Göppingen and
Wohlenberg in
Hannover –
two partners,
one idea: VDF.

Copyright by Boehringer
Printed in the Federal Republic of Germany
by W. Jungmann GmbH & Co., D-7320 Göppingen
Boe 225 e/4.80

BOEHRINGER
Göppingen.

Postal Address:
Gebr. Boehringer GmbH
Postfach 220
D-7320 Goeppingen
Telephone(0 71 61) 201-1
Telefax (0 71 61) 201353
Telex 07 27 708 boe d

Boehringer: a member of the
Oerlikon-Bührle Group.