

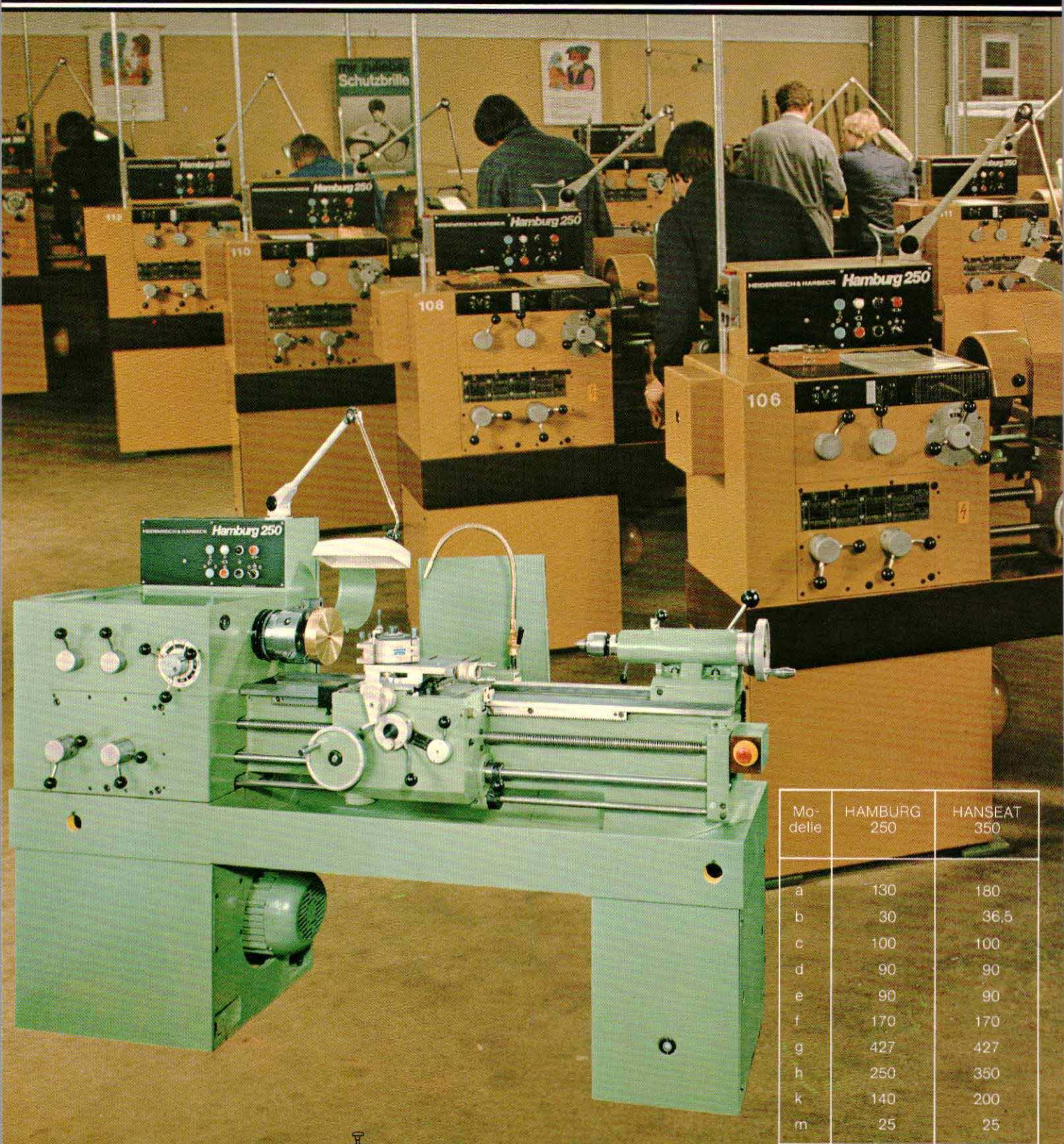

Drehen

HEIDENREICH & HARBECK

Hamburg 250



Mo- delle	HAMBURG 250	HANSEAT 350
a	130	180
b	30	36,5
c	100	100
d	90	90
e	90	90
f	170	170
g	427	427
h	250	350
k	140	200
m	25	25

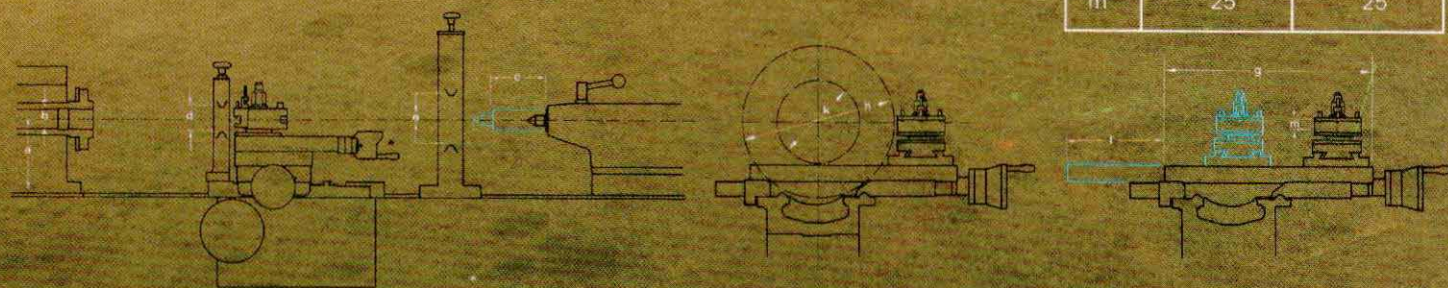

Hanseat 350

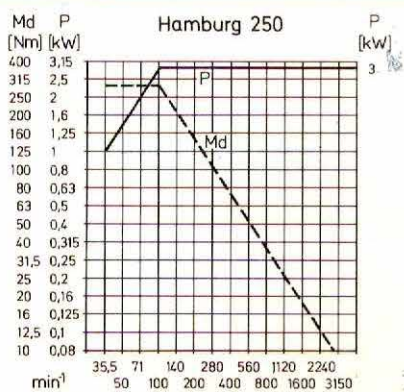

Hanseat 480

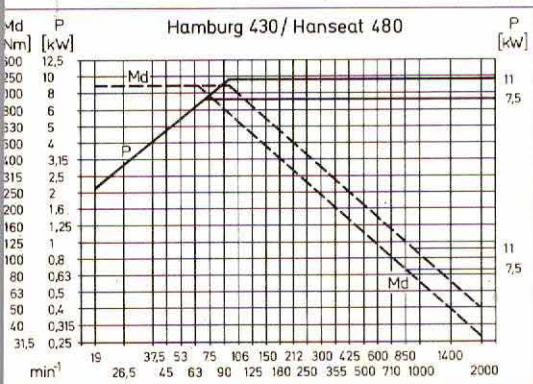
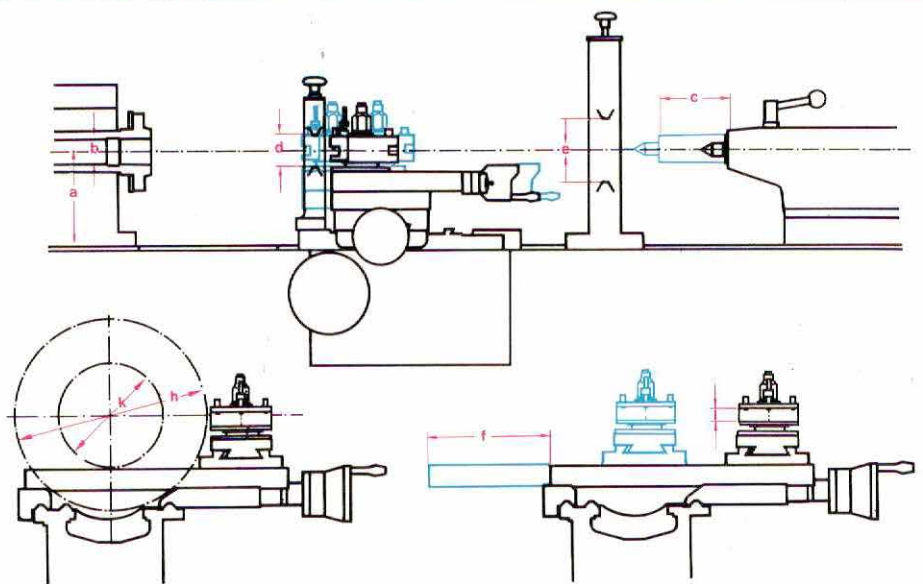
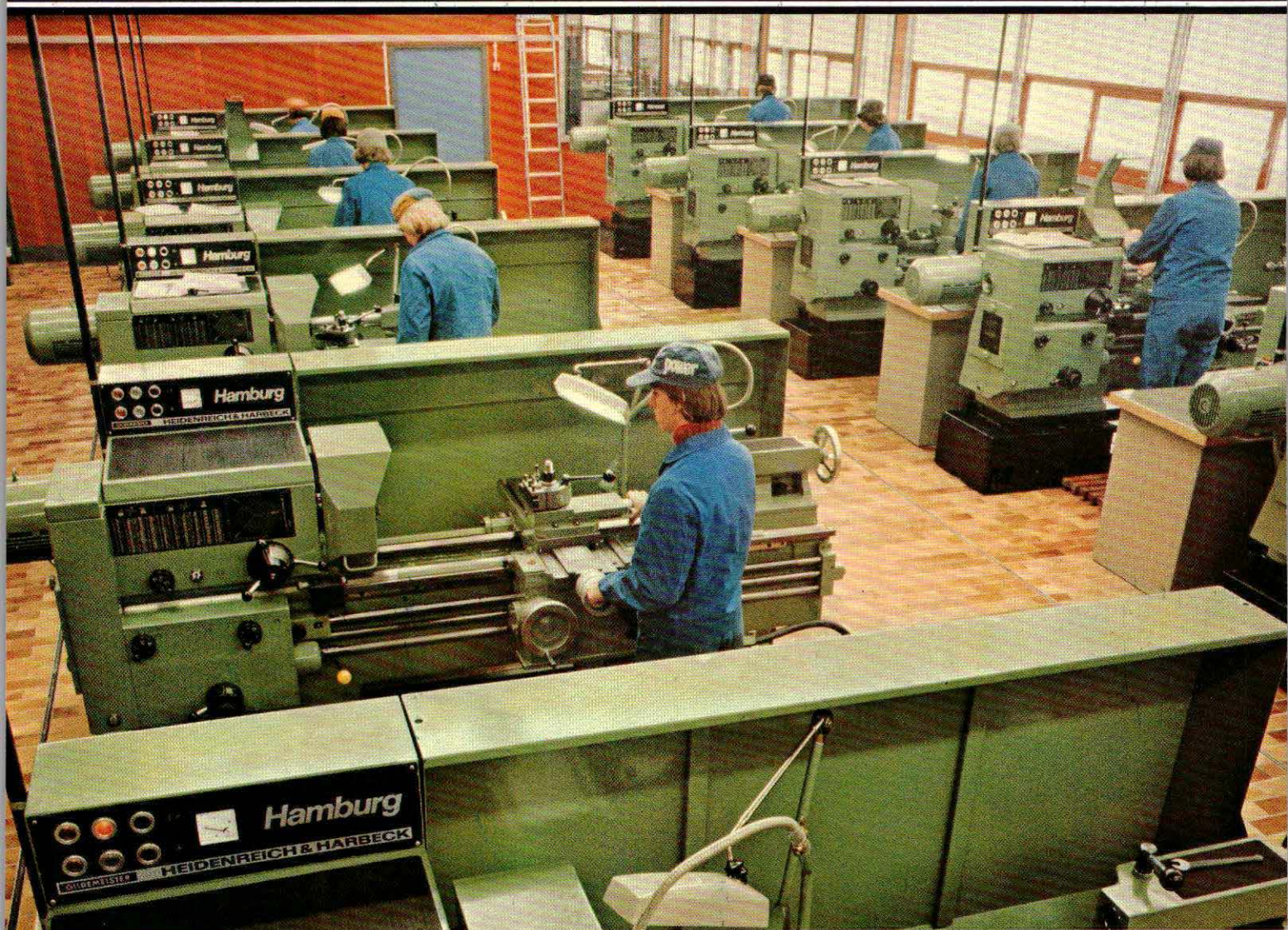

Modelle	a	b	c	d	e	f	h	k	l
HAMBURG 430	210	56	155	72	250	275	430	235	25
HANSEAT 480	240	56	155	125	250	305	480	295	25

Hamburg 540

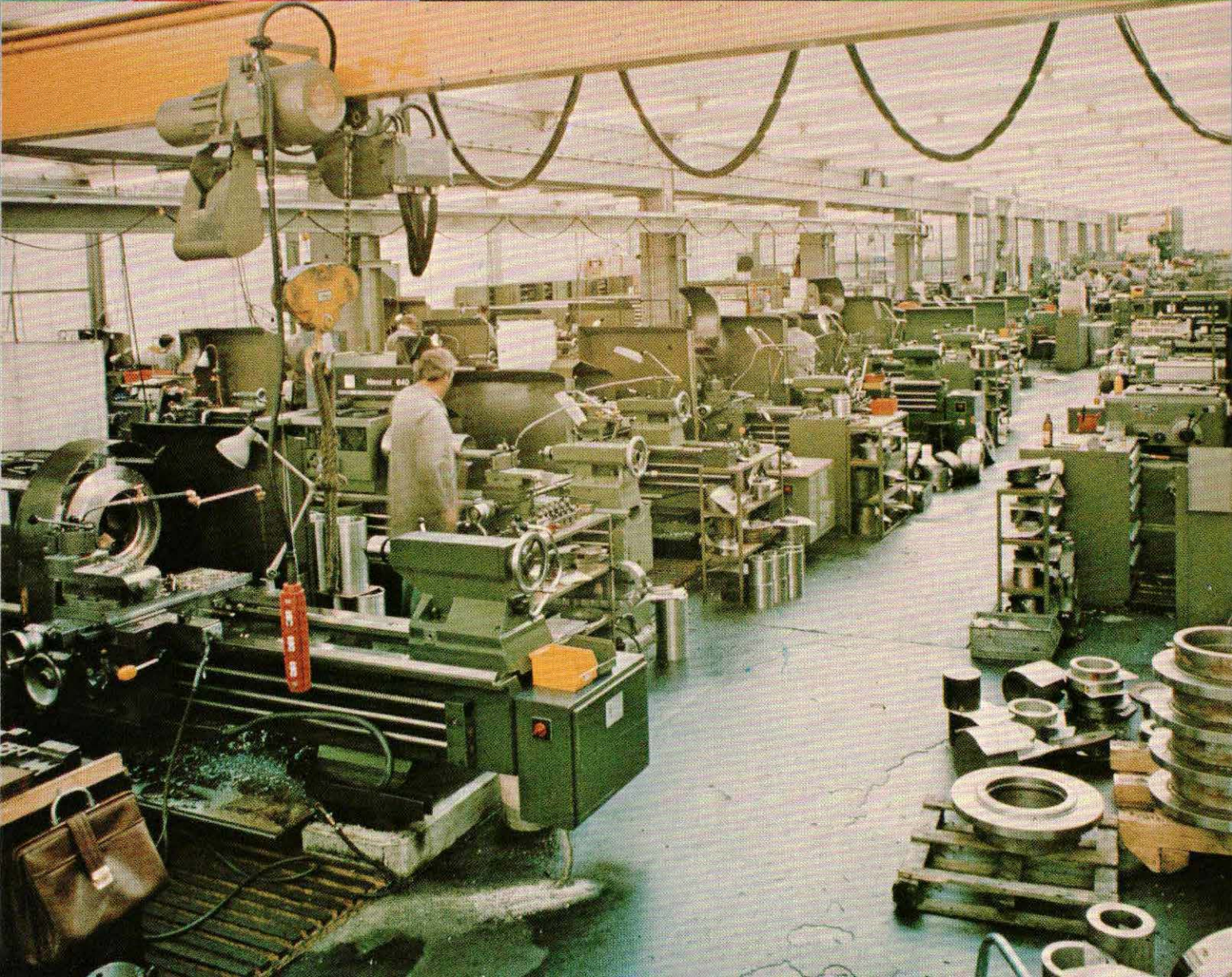
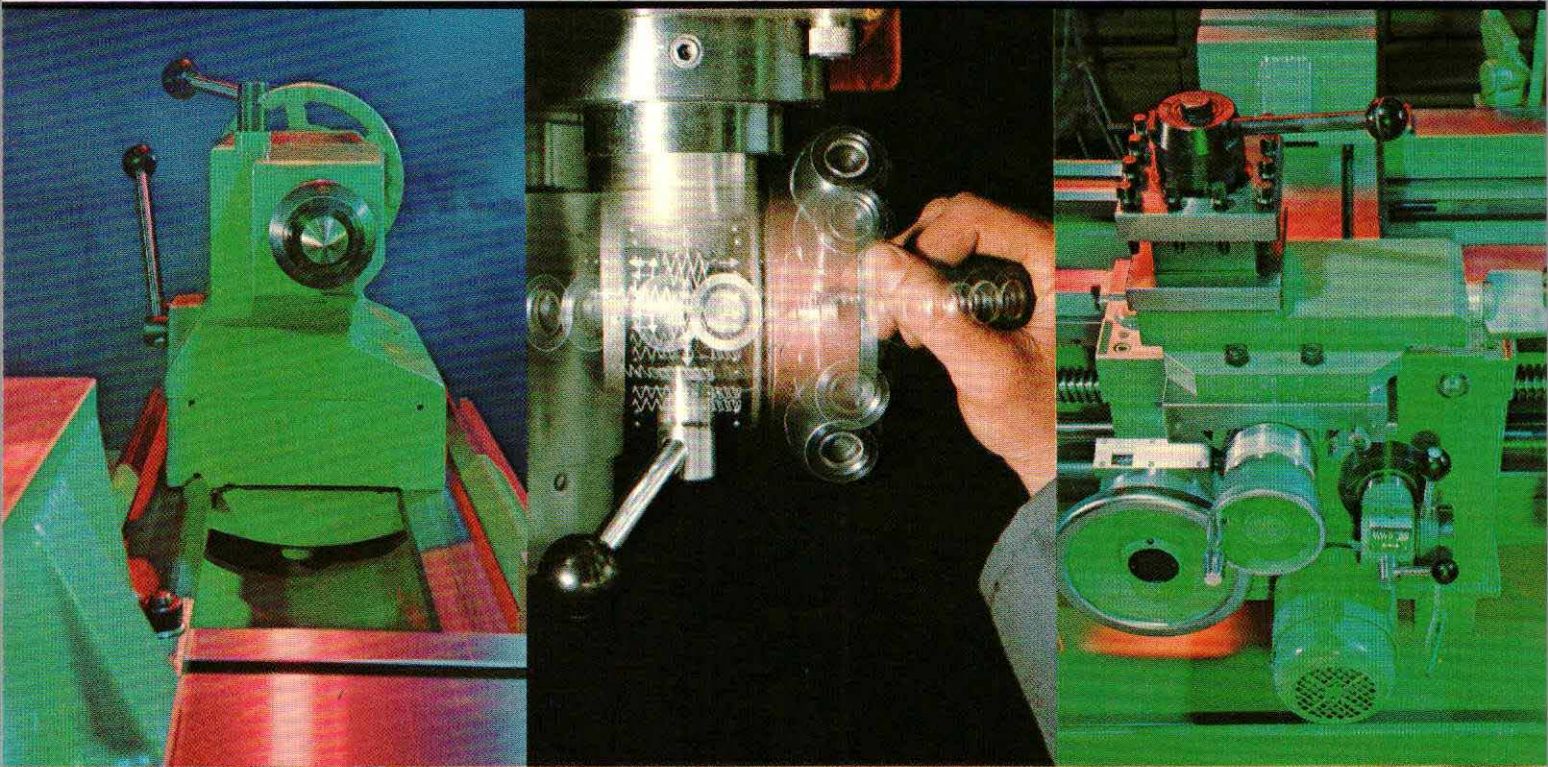

Hanseat 640

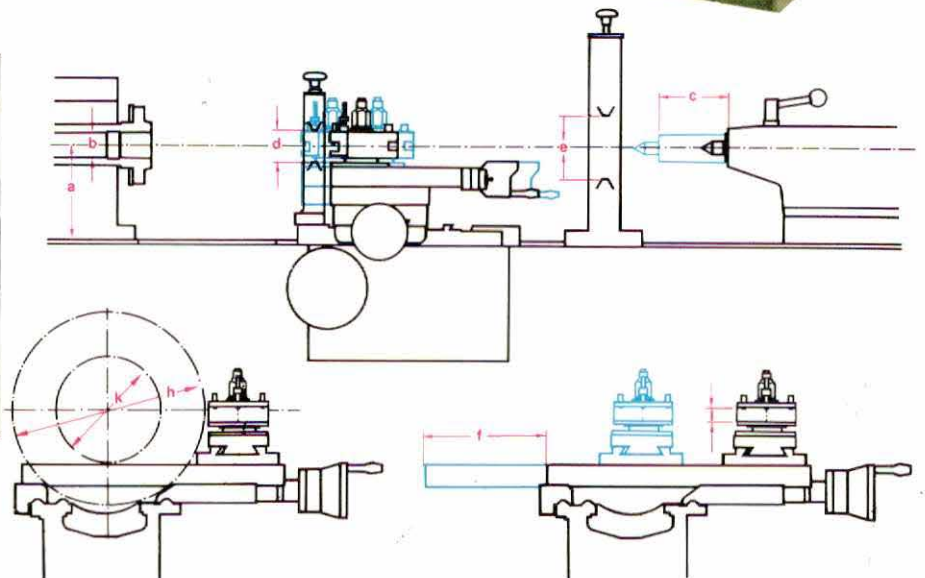
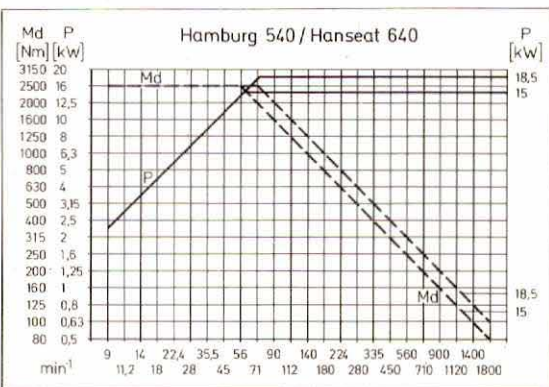
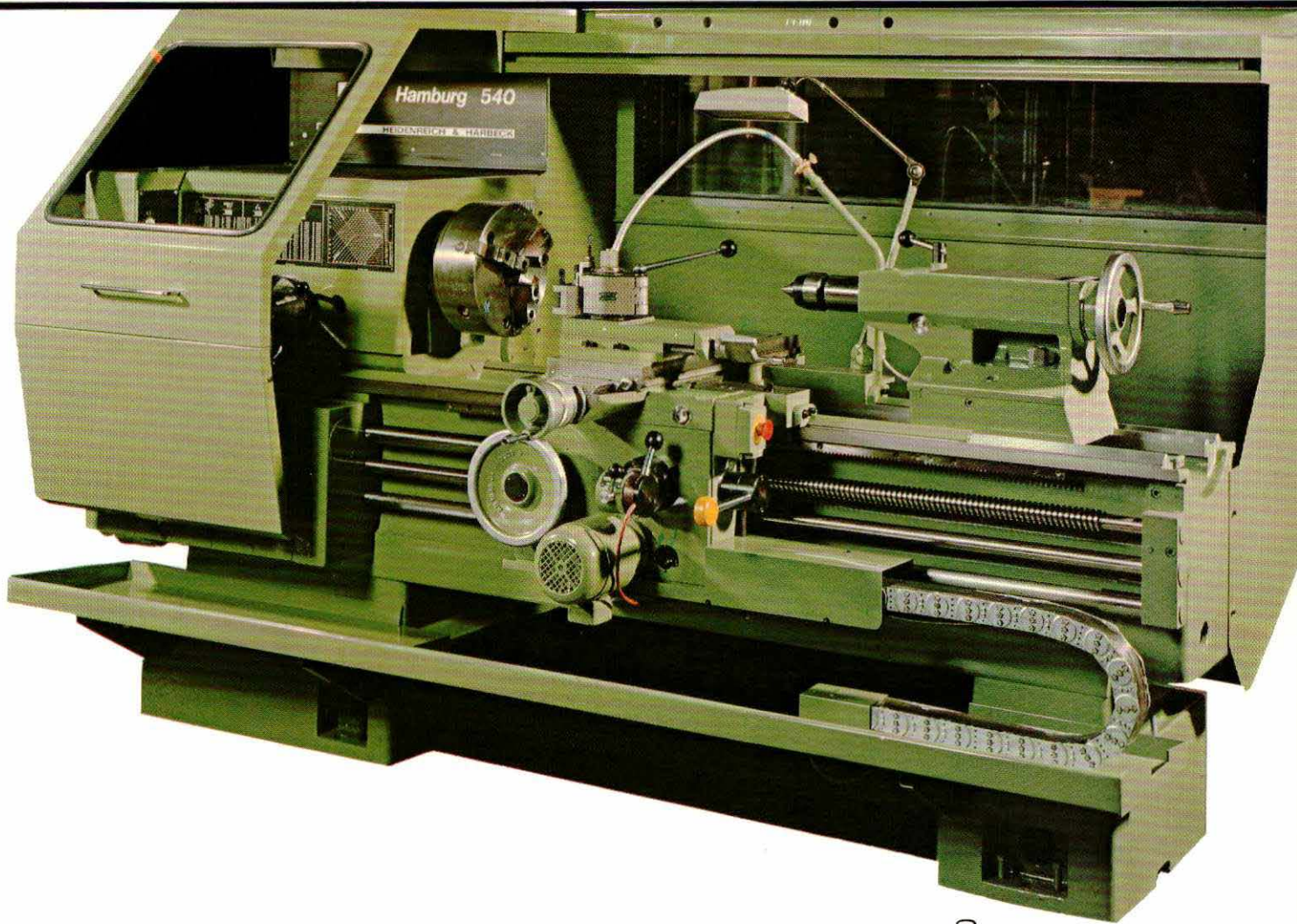

Modelle	a	b	c	d	e	f	h	k	m
HAMBURG 540	265	65	225	250	315	410	540	280	32
HANSEAT 640	315	65	225	250	400	410	640	380	32

Hamburg 840

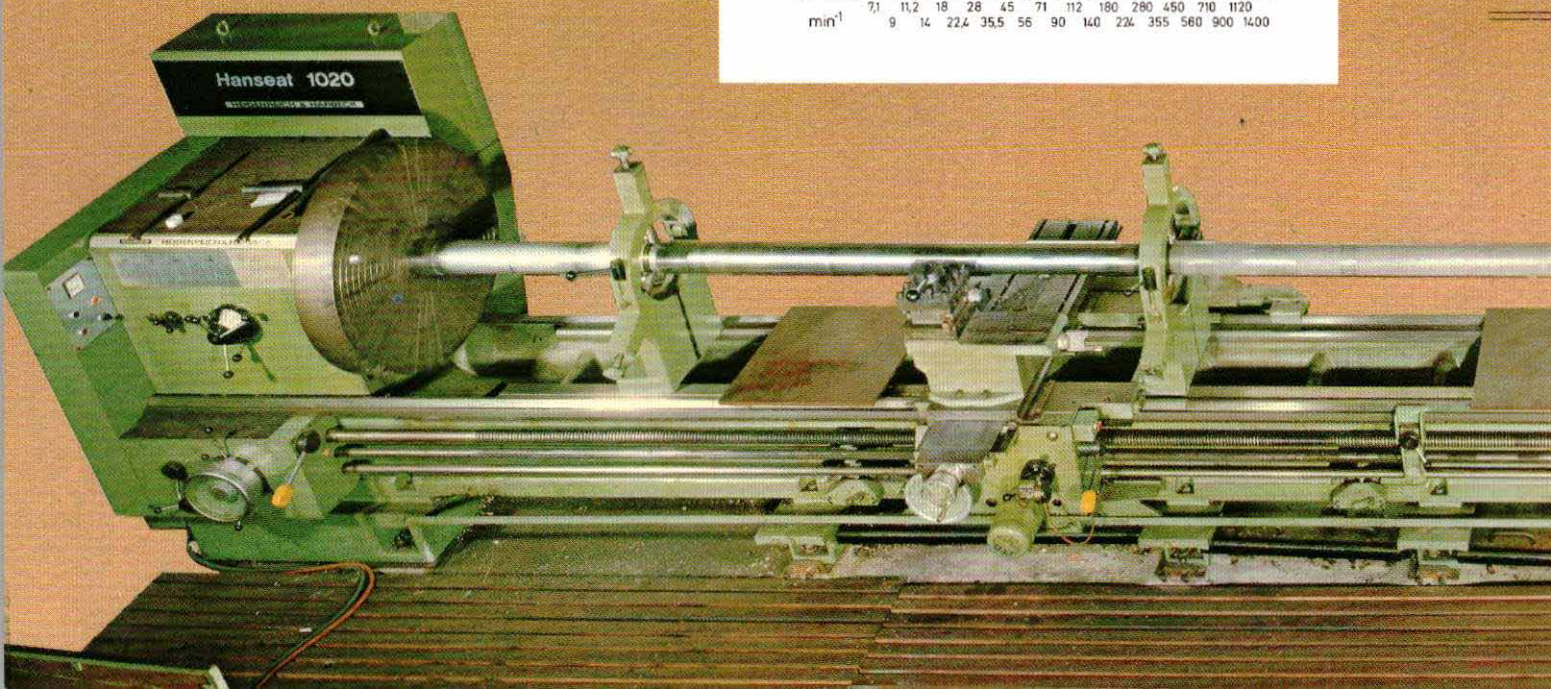
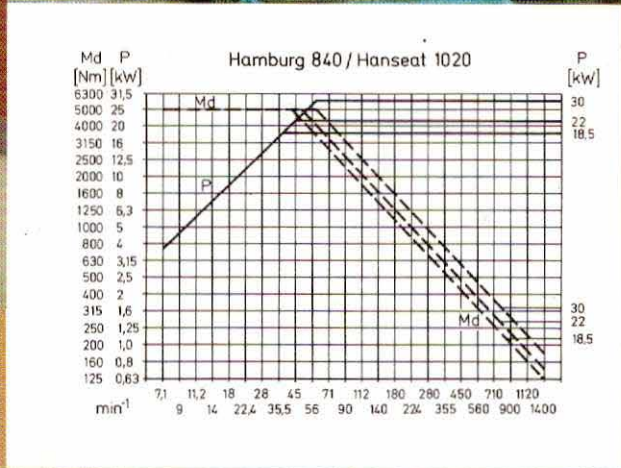
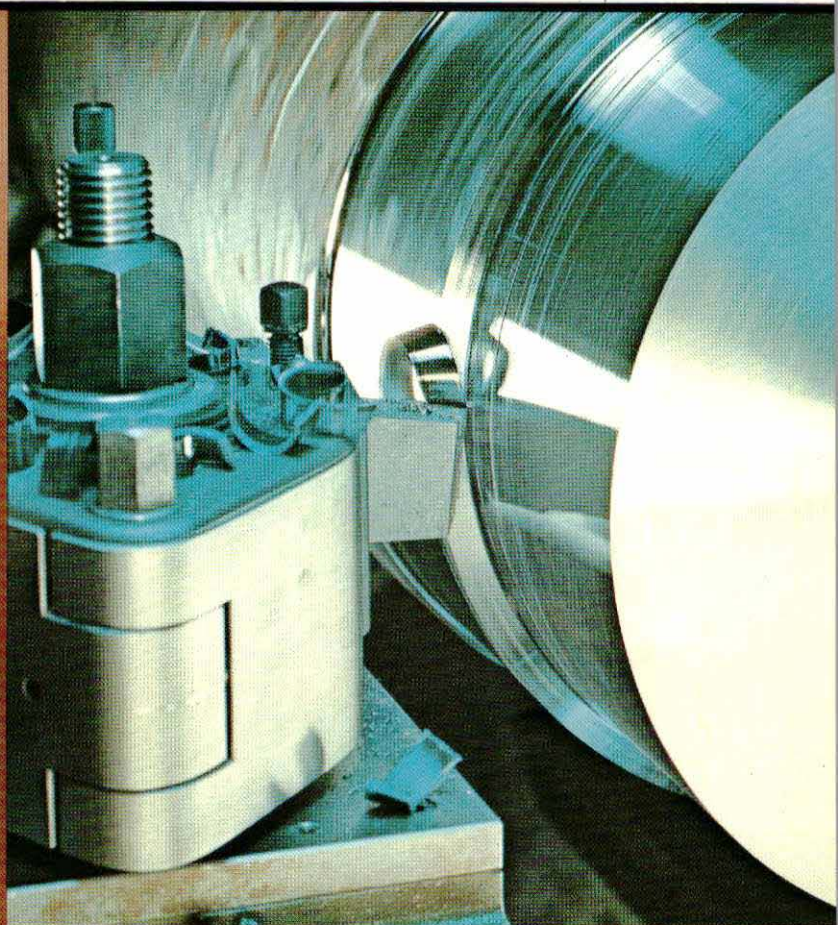

Hanseat 1020

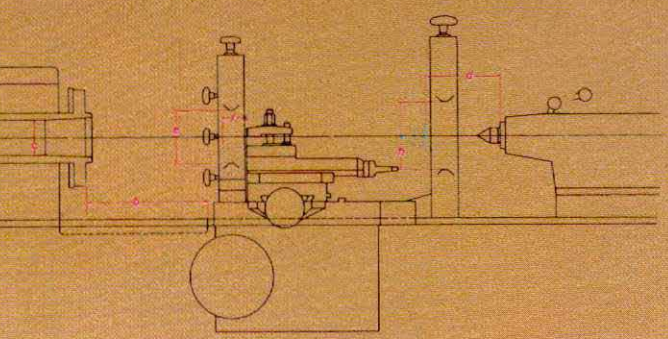
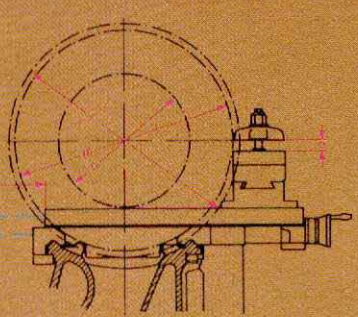
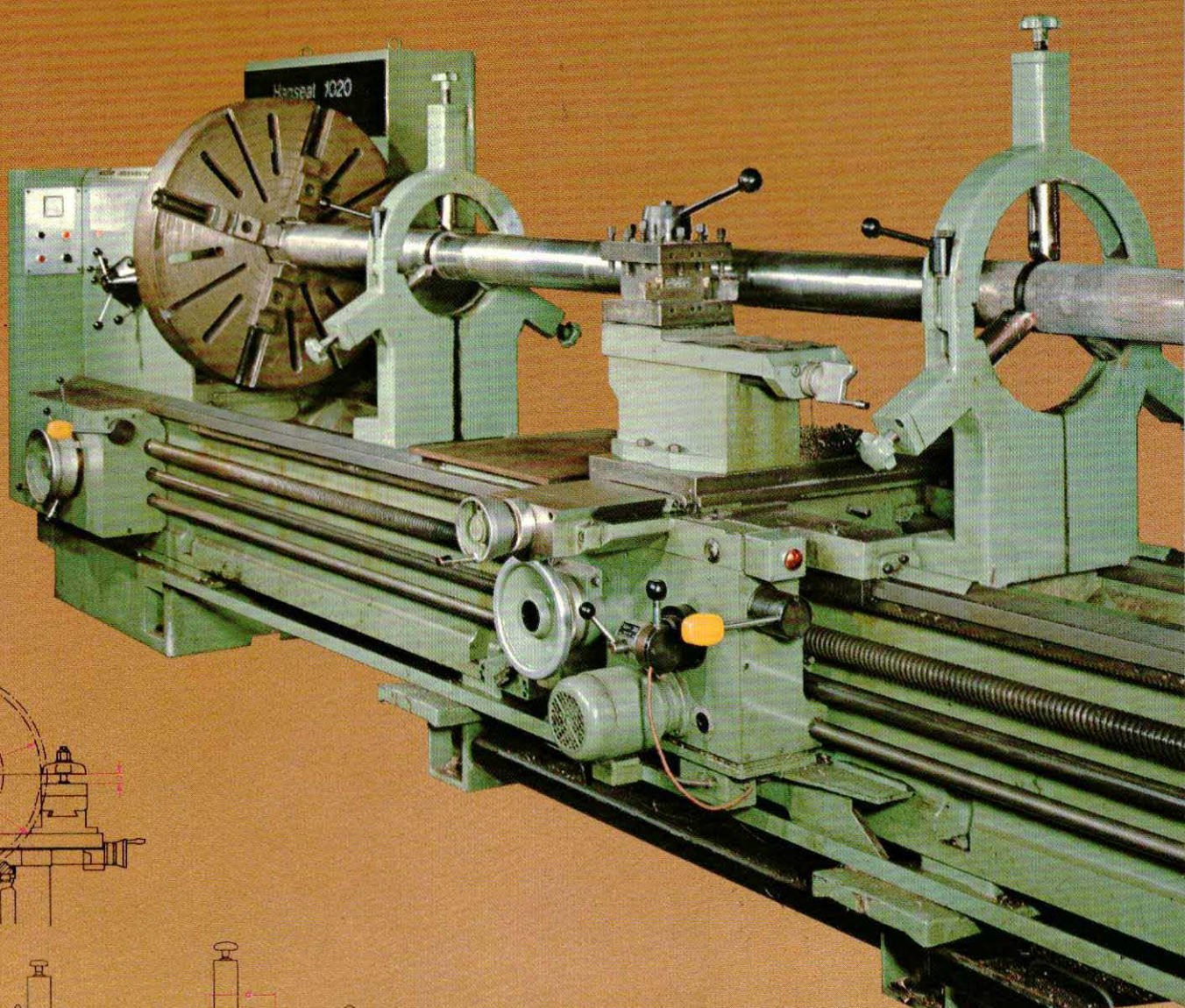

Modell	a	b	c	d	e	f
HAMBURG 840	400	410	128	300	350	260
HANSEAT 1020	500	410	128	300	350	260
	h	k	l	m	n	o
	600	550	900	840	515	40
	600	550	1070	1025	715	40

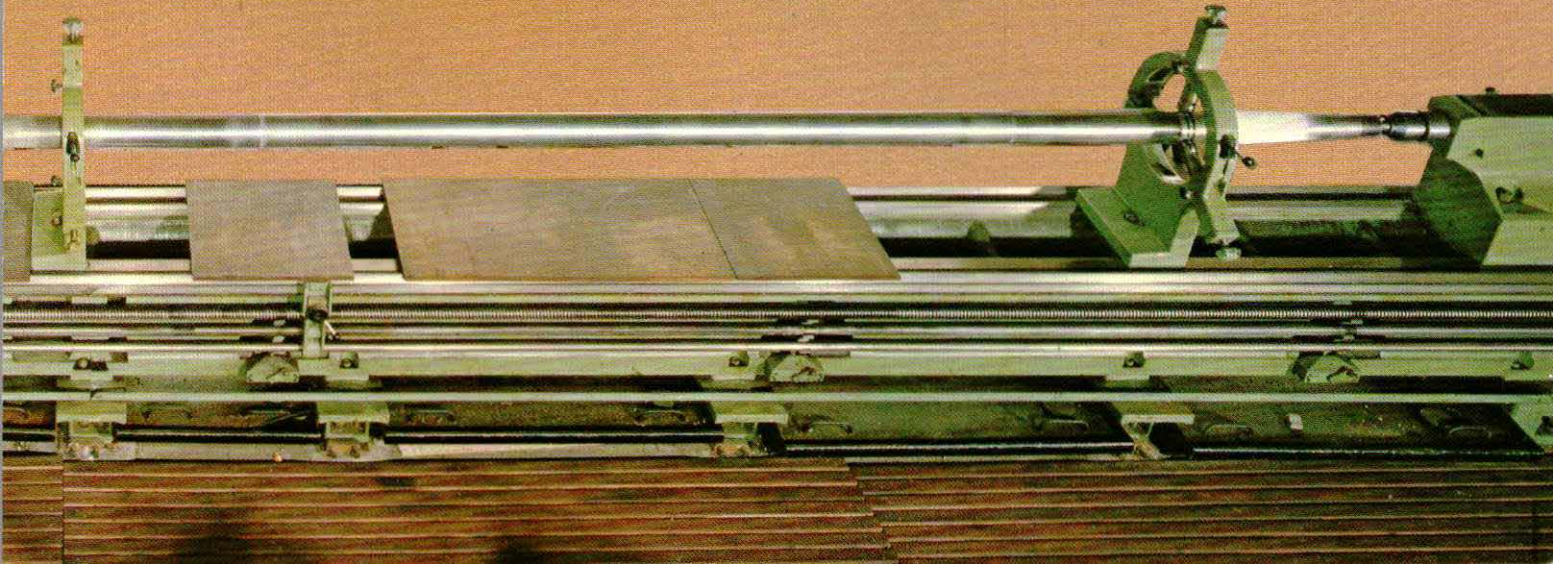

Hamburg 840

electronic

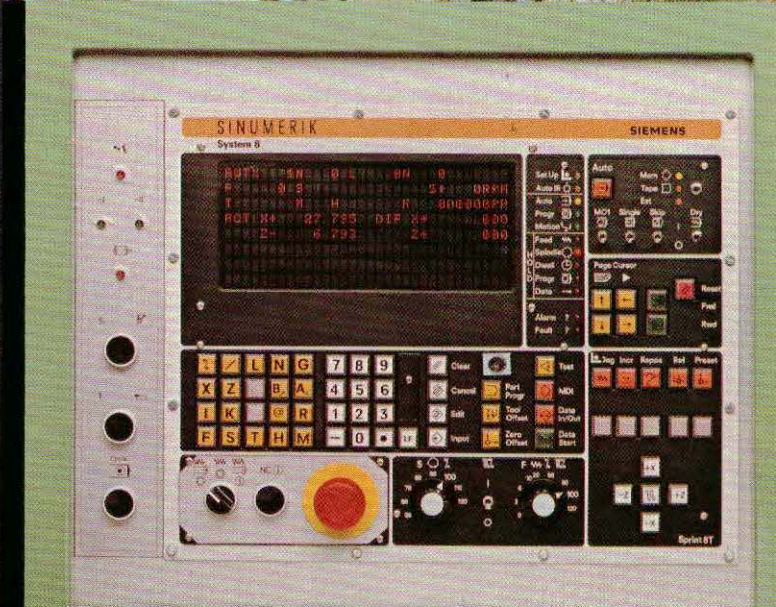
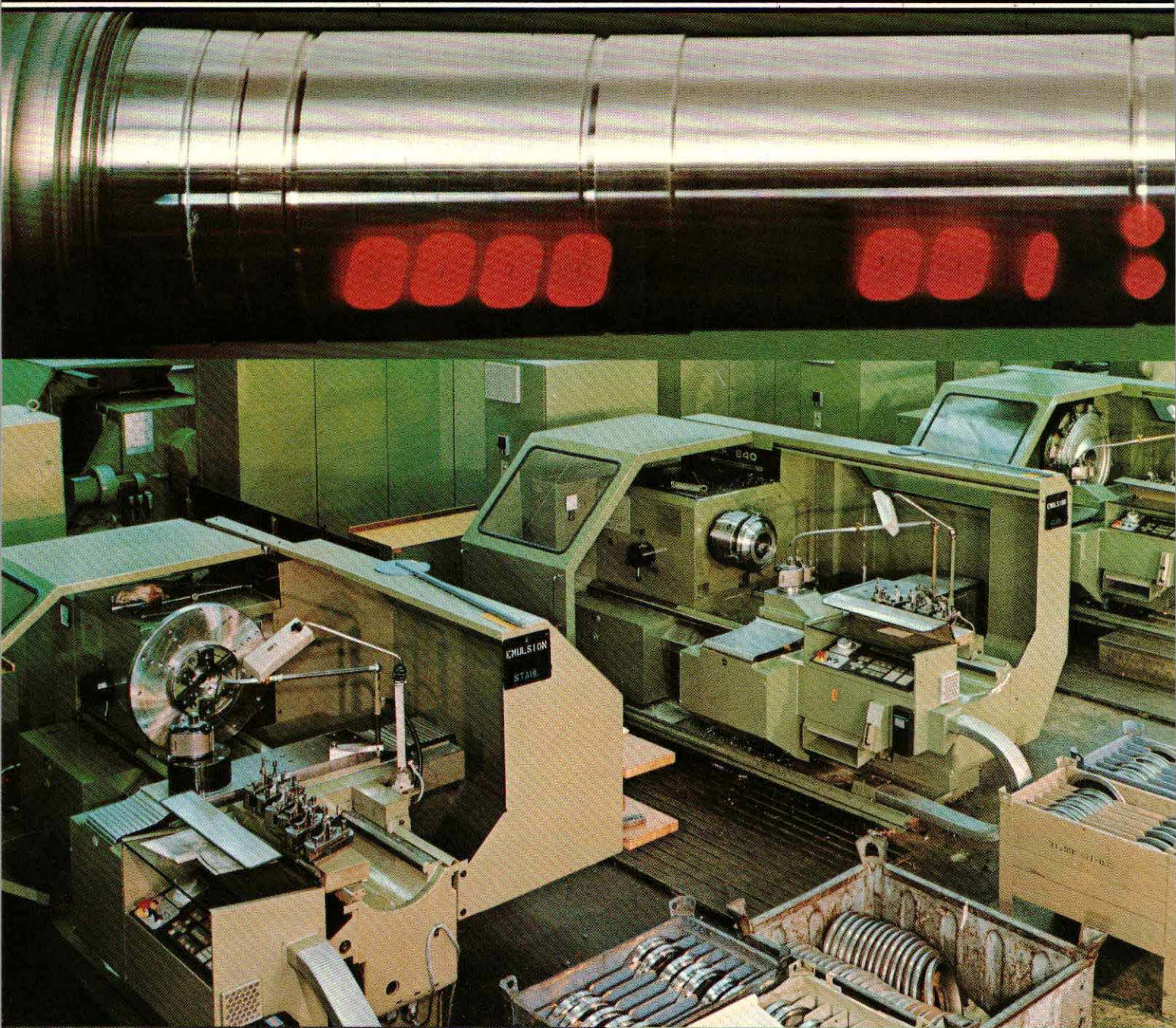

Hanseat 1020

electronic

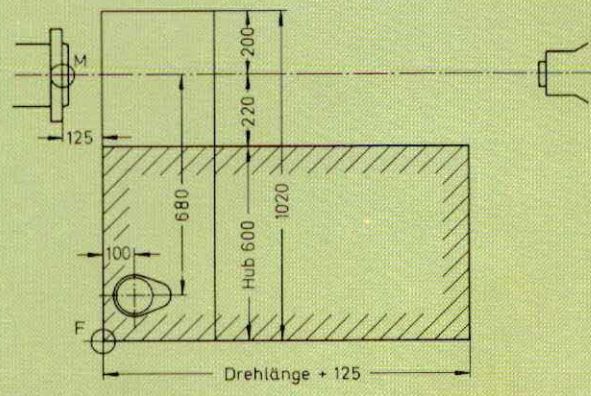
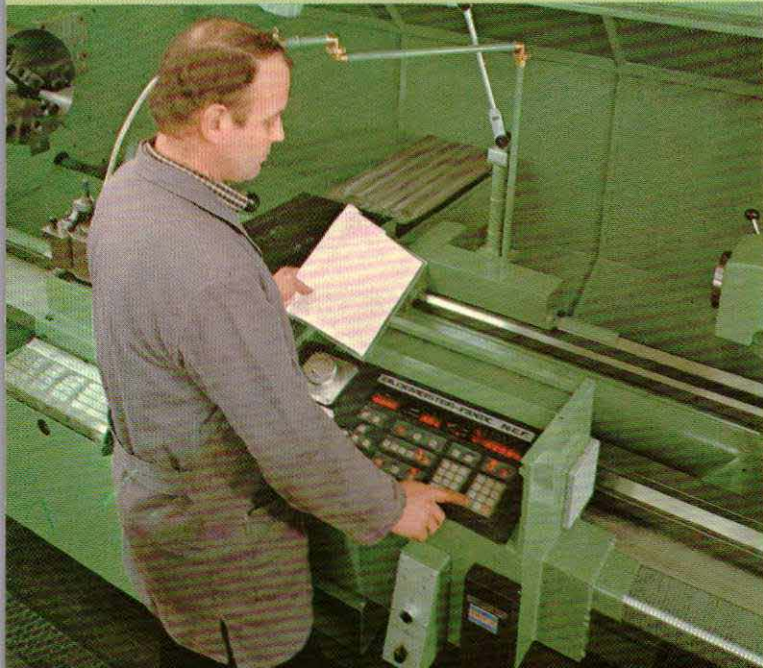
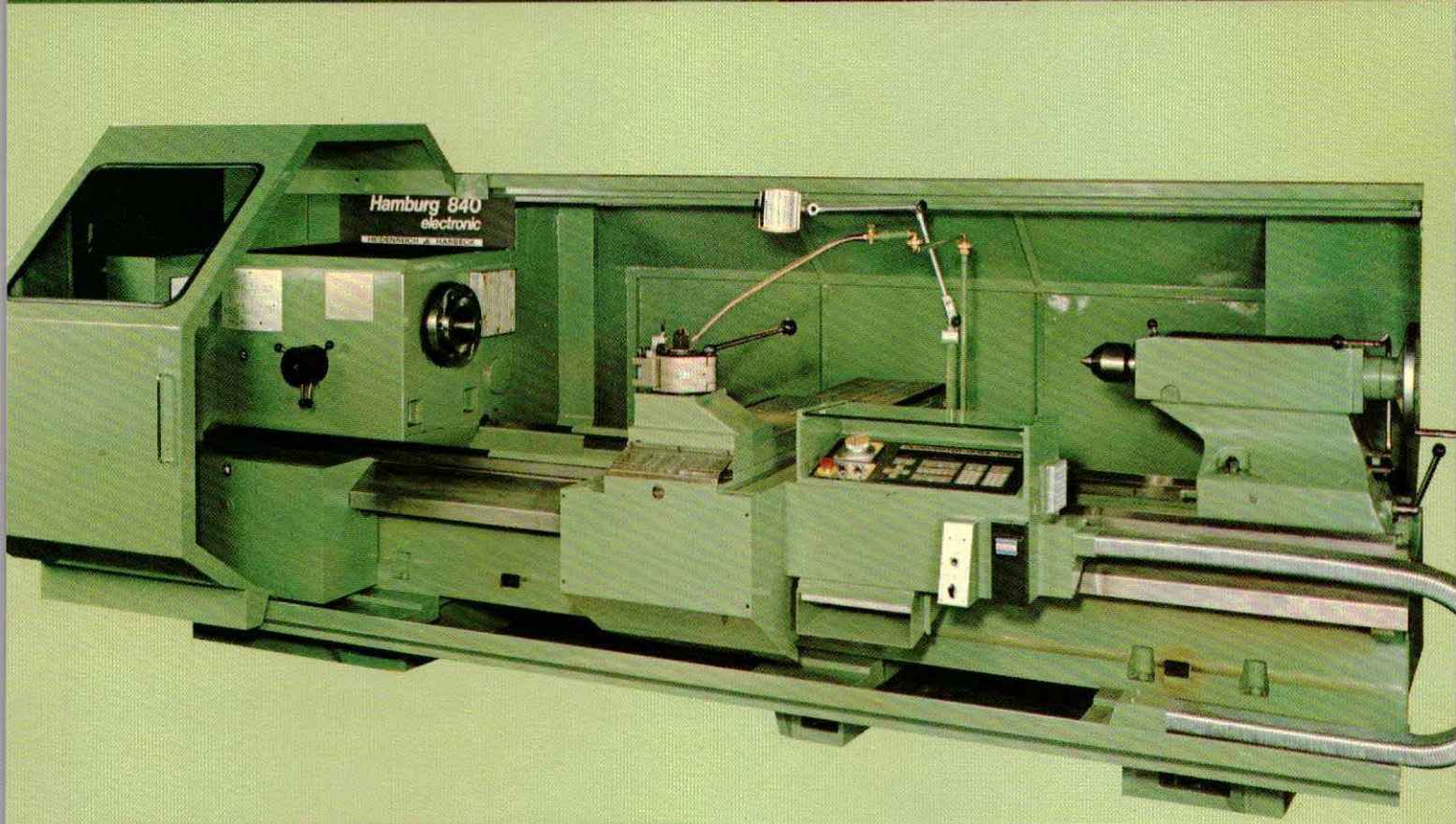
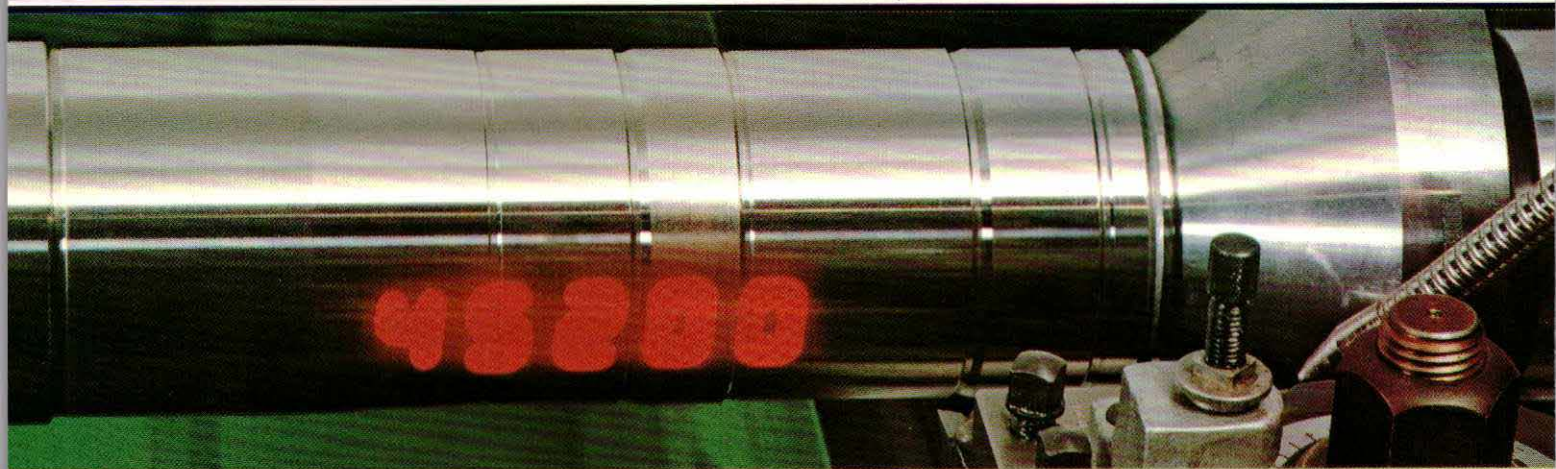

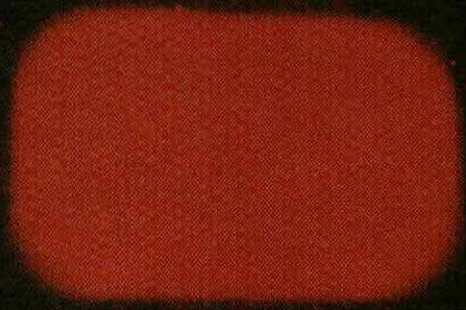

HEIDENREICH & HARBECK · Werkzeugmaschinenfabrik GmbH
Ein Unternehmen der GILDEMEISTER-Gruppe

Wiesendamm 30, 2000 Hamburg 60, Telefon (040) 29 89 1, Telex 211 174 (huh d)